

City of Hart, Michigan
CITY COUNCIL AGENDA - AMENDED
January 26, 2021, 7:30 PM
NOTICE OF REMOTE/HYBRID MEETING PUBLIC MEETING

**THIS NOTICE IS GIVEN AND PUBLISHED PURSUANT TO
MICHIGAN DEPARTMENT OF HEALTH AND HUMAN SERVICES
EMERGENCY ORDER UNDER MCL 333.2253 – GATHERING PROHIBITION AND
MASK ORDER AND PA 228 OF 2020 AMENDMENT TO SECTION 3 OF PA 267 OF 1976
OPEN MEETINGS ACT**

Please click the link below to join the webinar:

<https://us02web.zoom.us/j/86051201076?pwd=SVF1dWpMYlkzcWFMOGVLSlhrQ2JFdz09>

Passcode: 100586

Or iPhone one-tap :

US: +13017158592,,86051201076#,,,,*100586# or +13126266799,,86051201076#,,,,*100586#

Or Telephone:

Dial(for higher quality, dial a number based on your current location):

US: +1 301 715 8592 or +1 312 626 6799 or +1 646 558 8656 or +1 253 215 8782 or +1
346 248 7799 or +1 669 900 9128

Webinar ID: 860 5120 1076

Passcode: 100586

International numbers available: <https://us02web.zoom.us/j/86051201076?pwd=SVF1dWpMYlkzcWFMOGVLSlhrQ2JFdz09>

1. Call to Order
2. Roll Call – Burillo, Evans, Hodges, B. Platt, Rybarz Jr., Splane, V. Platt
3. Pledge of Allegiance
4. Appointment – City Clerk/Treasurer – Karla Swihart
5. Public Comments – **Public comment on any matter that is not included on the agenda for a public hearing by the Council. We ask that you please limit your comments to 3 minutes**
 - a. **Public Hearing:** City of Hart Safe Routes to School Application
 - b. Correspondence, Events, Presentations
6. Consent Agenda:
 - a. Approval of Agenda
 - b. Approval of Minutes from January 12, 2020.
 - c. Bills, Claims, Payroll
 - d. Reports of Boards, Commissions, and Committees
 - e. Department Reports – Police/BioPure/Public Works/Energy/♥C&E Dvlp.
 - f. **Special Event Permits:**
 - i. *Vintage Snowmobile Show and Swap Meet*
 - ii. *Music on the Commons*
 - iii. *Hart Sparks*
7. Action Items
 - a) Resolution 2021-02 Accept Bids for new roof at Sackrider Church and Award project to Juan Time Roofing
 - b) Resolution 2021-03 Resolution supporting Safe Routes to School Grant Application

With advance notice of seven calendar days, the City will provide interpreter services at all public meetings, including language translation and signage for the hearing impaired. Call 231-873-2488. La Ciudad proporcionará servicio de intérprete para esta reunión pública si se pide con siete días de anticipación, lo cual incluye la traducción de idioma y letreros para los con una discapacidad auditiva. Llame al 231-873-2488.

8. Discussion Items
 - a. Intergovernmental Agreement w/Shelby Township – Community and Economic Development Assistance
9. City Manager Report
10. Communications from the Mayor and Council
 - a. Appointment: Nichole Russel – HEART Board
11. Adjournment –

Access is provided through the Michigan Relay Service for individuals with speech or hearing impairments. <https://hamiltonrelay.com/michigan/index.html>

- ♥ Community and Economic Development (includes HEART)



CITY OF HART
407 S. STATE ST.
HART, MI 49420
COUNCIL PROCEEDINGS
January 12th, 7:30 pm
MINUTES – DRAFT

PRESENT VIA ZOOM: Mayor Vicki Platt, Councilors: Rob Splane Jim Evans, Braxton Platt, Fred Rybarz, Dean Hodges, and Catalina Burillo.

ABSENT: None

OTHERS PRESENT City Manager – Lynne Ladner, Deputy City Clerk – Cheri Eisenlohr, Brooke Bectel.

Mayor Platt called the meeting to order; following the roll call, the Mayor lead the Council in the pledge of allegiance

APPOINTMENT: City Clerk/Treasurer – Karla Swihart

- o Ayes 7 Nays: 0 Absent: 0

PUBLIC COMMENTS:

- Brooke asked to speak on the first reading of Ordinance 2021 01. Brooke apologized she was unable to make the Planning Commission meeting held on January 7th. Still, she wanted to bring up a couple of points about they want to add living space to the 1st floor now that they no longer do screen printing out of there anymore also seen that the building has always been commercial. Maybe that is why the Planning Commission wanted to keep the building as a commercial, which made her think back when they owned the building across the street; that building was always commercial but was switched to residential before they bought it. Also, everything to the west of their building is all residential. We will discuss more when the Action item comes up.

CORRESPONDENCE, EVENTS, PRESENTATIONS:

- Raymond talked about the Hart Hills bike race, and they are still moving forward with the race. Face masks are mandatory at the start of the race and put back on once you have finished the race.

VACANCY APPOINTMENT: Board of Review – Property Taxes, There is a vacancy due to the passing of elected board member Bill Wells for a term to expire November 2022. An applicant Steven Rossiter who lives at 25 S Orchard Street. Mr. R. Splane motioned to approve applicant Steven Rossiter as Board of Review appointment, supported by Mr. J. Evans, all ayes, the motion carried.

- o Ayes: 7 Nays: 0 Absent:

CONSENT AGENDA:

- A. Approval of Agenda
- B. Approval of Minutes from December 12th, 2020.
- C. Bills, Claims, Payroll
 - a. 12/22/2020 \$339,983.05, 01/12/2021 \$811,268.50 Grand Total: \$1,151,251.55
- D. Reports of Boards, Commissions, and Committees.
- E. Department Reports – Police/BioPure/Public Works/Energy/C&E Dvlp.
- F. Special Event Permit – Hart Hills Gravel Bike Race 2021
- Mr. Evans motioned to approve, supported by Mr. Splane, the motion carried.
 - Ayes: 7 Nays: 0 Absent: 0

ACTION ITEMS:

Ms. Ladner addressed the following Action Items:

- Resolution 2021-01 Set Pay Rates for City Clerk/Treasurer, Deputy Clerk-Treasurer – A/P and Payroll and Community and Economic Development Director.
 - o Mr. B. Platt moved to approve, supported by Mr. Evans
 - Ayes: 7 Nays: 0 Absent: 0
- Ordinance 2021-01 To Amend the zoning map to rezone 311 E. Main St, Hart Mi (020-209-008-00) from B-1 Central Business District to A – Residential – **First Reading no Action to be taken.**

On Jan 7th, 2021, The Planning Commission considered at their regular meeting the application for rezoning of parcel number 020-209-008-00, commonly known as 311 E Main St. The application was submitted to the PC by property owners.

After discussions and clarifications, as well as reviewing the application submitted and subsequent letter submitted by the property owner as they were not able to attend the meeting, the board considered a motion to recommend denial of the rezoning application to the City Council.

The Council has two options at this point.

1. The Council can accept the recommendation of the Planning Commission, and if not interested in continuing to consider the request, they may deny the request. This could be done by a motion to accept the Planning Commission's recommendation and decline to consider the first reading of Ord. 2021-01
2. The Council can receive the recommendation of the Planning Commission, but if the Council wants time to further consider the application themselves. This could be done by a motion along the lines of moving to accept the recommendation of the Planning Commission and acknowledge the first reading of Ord. 2021-01.

Ultimately, the Council has the final decision on requests of this type, but as an advisory body to the Council, the Planning Commission is tasked with the heavy lifting on items such as these, and they have considered the facts, the owner's statement, and made a recommendation to the Council.

- J. Evans motioned to table the Ordinance 2021-01 to the 1st Council meeting on Feb 9th and allow for the property owner to attend the next Planning Commission meeting and make their case in person as well as any member of the City Council to sit in on the meeting as well to get any questions answered, supported by C. Burillo.

▪ Ayes: 7 Nays: 0 Absent: 0

DISCUSSION ITEMS: None

CITY MANAGER'S REPORT:

- 2021 has started as a sequel to 2020 as we are still working remotely. We are still wearing a mask.
- Working on a policy to bring in front of Council in Feb regarding Covid vaccinations as the federal support for extended coronavirus sick leave expired Dec 31th 2020, we have several individuals who are on the fence about getting the vaccine. Employees who receive the vaccine and contracted the virus would be entitled to paid time off and not have to use ETO. Employees who do not receive the vaccine and contract the virus would **NOT** be entitled to PTO and would have to use ETO.
- Nicole and I had a meeting last week with PSE (power supply engineering); they are contracted thru a grant by MMEA to do a feasibility study for broadband internet for specific municipal electric utilities. They will be giving their presentation in front of the Council in Feb to see if this would be something the City would like to consider and how to rollout.
- Safe routes to the school is in their final stages. The final public hearing will be in front of the Council at the next meeting.
- End of the year reporting is completed.
- We should be hearing back on the water assets management grant and meeting with Barbara from Prein & Newhof about EDA grant to improve our wastewater facility.
- I will be out of the office from Jan 30th thru Feb 5th.

COMMUNICATIONS FROM THE MAYOR AND COUNCIL:

- Mayoral board and Committee appointments: Fred Rybarz Jr – Lake Board, Cemetery Board & Parks & Recreation, Catalina Burillo – Parks & Recreation, Historic District & Power Board (Council Alternate), Dean Hodges – Power Board, Zoning Board of Appeals & Lake Board, Jim Evans – Library, Board of Review, Property Taxes (Mayoral Designee) & Cemetery Board, Braxton Platt – HEART, Personnel & Finance, Rob Splane – HEART, Planning Commission, Personal & Finance.
- The Mayor is interested in doing a work session with this group to get a better understanding of how to operate as a council as well as the ability to communicate on our strengths and weaknesses. Maybe quarterly.
- Do you feel that Lynne needs to read the memos? Or if they are put up on a screen for everyone to view.

- Paul Cutter wanted to make sure we pay tribute to Wm. Wells and all the good things he has done for the City of Hart. Mayor V. Platt suggested we all take a moment to honor and acknowledge Mr. Wells as a Thank-you for service rendered to the City.

Closed Session:

- B. Platt motioned we adjourn and move into a Closed session as permitted under section 8(e) of the Open Meetings Act, to consult with our attorney regarding trial or settlement strategy in Wittman V. City of Hart et al. I to include City Manager L. Ladner, City Clerk K. Swihart, and Lawyer A. VanderLaan and Supported by R. Splane the motion carried.
 - Ayes: 7 Nays: 0 Absent: 0
- C. Burillo motioned we return to open session and supported by J. Evans

ADJOURN:

- There being no further business to come before the Council, the meeting adjourned at 9:41 pm upon a motion by B. Platt and supported by J. Evans. The next regularly scheduled meeting will be on January 26, 2021, at 7:30 pm, and will be held virtually.

Respectfully Submitted



Karla Swihart City Clerk

ACCOUNTS PAYABLE

1/22/2021, 10:29 AM

Payables Date: 1/26/2021	Description	Total	General +	DPW	Energy	BPTF	Water
Axon	Battery Packs - Police	\$ 184.50	\$ 184.50				
Blue Cross Blue Shield	Feb. Ins. Prem.	\$ 10,308.89	\$ 4,099.65	\$ 1,148.34	\$ 2,185.20	\$ 2,468.95	\$ 406.75
Blue Cross Blue Shield Medicare	Jan. Ins. Prem.	\$ 3,076.44	\$ 1,625.39		\$ 1,271.60	\$ 89.73	\$ 89.72
Cannon/Eaton	Meters	\$ 1,205.64			\$ 1,205.64		
Charter	Hart Commons - Internet	\$ 109.99			\$ 109.99		
Clayton, Trev	Deposit Refund	\$ 200.00			\$ 200.00		
Dacott	November, 2020 Purchase Report	\$ 650.00			\$ 650.00		
Delta Dental	Jan. Ins. Prem.	\$ 1,238.56	\$ 504.38	\$ 89.37	\$ 386.65	\$ 210.92	\$ 47.24
DTE	Natural Gas	\$ 314.29			\$ 314.29		
Fisher LP Gas	Utilities	\$ 540.83			\$ 540.83		
Frontier	Energy #2	\$ 47.85			\$ 47.85		
Frontier	JGP	\$ 129.04	\$ 129.04				
Frontier	Dam	\$ 117.28			\$ 117.28		
Hach	Lab Supplies	\$ 265.97				\$ 265.97	
Hart Cemetery Commission	2020 Summer Taxes	\$ 210.18	\$ 210.18				
JJ Keller	Labor Law Posters	\$ 589.20	\$ 147.30	\$ 147.30	\$ 147.30	\$ 147.30	
Lawson-Fisher	2020 Water Quality Study/Dam	\$ 658.23			\$ 658.23		
LEAF	Police Copier Lease fee	\$ 39.00	\$ 39.00				
MMEA	2021 Dues	\$ 7,727.00			\$ 7,727.00		
MPPA	Purchased Power	\$ 11,612.04			\$ 11,612.04		
MWEA	2021 Dues - Kies	\$ 77.00				\$ 77.00	
Pixel Grafix	Envelopes	\$ 142.95	\$ 142.95				
Pixel Grafix	Council Handbooks	\$ 2,609.16	\$ 2,609.16				
Pixel Grafix	Downtown Banners	\$ 2,352.00	\$ 2,352.00				
Power Line Supply	Parts/Supplies	\$ 383.30			\$ 383.30		
Pranger Property Mgmt	City Hall Cleaning Svcs	\$ 168.00	\$ 168.00				
Skipski, Kevin	Reimburse Instructor Fee	\$ 55.00	\$ 55.00				
Uline	Rugs - Energy Dept.	\$ 799.83			\$ 799.83		
Windridge	Shirts/Hats	\$ 354.00				\$ 354.00	
X-Cel Chemical	Electrostatic Sprayer	\$ 1,395.00	\$ 1,395.00				
		\$ -					
	Subtotal	\$ 47,561.17	\$ 13,661.55	\$ 1,385.01	\$ 28,357.03	\$ 3,613.87	\$ 543.71
HAND CHECKS/ACH							
Alerus - ACH	City Share 401 Retirement	\$ 2,782.84	\$ 2,782.84				
US Postmaster	Postage	\$ 129.26	\$ 129.26				
Freed Mgmt	15% of Contract	\$ 10,500.00	\$ 10,500.00				
		\$ -					
		\$ -					
		\$ -					
	TOTAL HAND CHECKS	\$ 13,412.10	\$ 13,412.10	\$ -	\$ -	\$ -	\$ -
	Sub-Total Regular Bills/Hand Checks	\$ 60,973.27	\$ 27,073.65	\$ 1,385.01	\$ 28,357.03	\$ 3,613.87	\$ 543.71
Gross Payroll	502	\$ 57,068.93					
	Sub-Total	\$ 57,068.93					
	GRAND TOTAL	\$ 118,042.20	\$ 27,073.65	\$ 1,385.01	\$ 28,357.03	\$ 3,613.87	\$ 543.71

PAYROLL AMOUNTS					
01/07/21					
Pay 501		GROSS PAY	OVERTIME	OPT-OUT	BASE PAY
Employee Code	Dept.		PAY		
FULL-TIME					
DCC	Office	\$1,691.20	\$0.00	\$0.00	\$0.00
MGR.	Office	\$3,640.80	\$0.00	\$0.00	\$0.00
DCC	Office	\$1,278.00	\$0.00	\$0.00	\$0.00
CC	Office	\$2,018.40	\$0.00	\$0.00	\$0.00
DCC	Office	\$1,820.00	\$0.00	\$0.00	\$0.00
PO	Police	\$174.72	\$0.00	\$0.00	\$0.00
PO	Police	\$2,150.40	\$0.00	\$0.00	\$0.00
PO	Police	\$2,542.83	-\$434.83	\$0.00	\$0.00
PC	Police	\$2,524.80	\$0.00	\$0.00	\$0.00
DS	Police	\$2,208.00	\$0.00	\$0.00	\$0.00
DPW1	DPW	\$2,194.14	-\$176.54	\$0.00	\$0.00
DPW2	DPW	\$2,219.36	\$0.00	\$0.00	\$0.00
DPW3	DPW	\$2,256.32	\$0.00	\$0.00	\$0.00
DPWS	DPW	\$2,436.00	\$0.00	\$0.00	\$0.00
BIOS	WW	\$2,886.40	\$0.00	\$0.00	\$0.00
BIOS	WW	\$2,219.36	\$0.00	\$0.00	\$0.00
BIOS	WW	\$2,429.39	-\$173.07	\$0.00	\$0.00
ENERGY1	Energy	\$3,236.88	\$0.00	\$0.00	\$0.00
ENERGY2	Energy	\$3,535.84	\$0.00	\$0.00	\$0.00
ENERGYS	Energy	\$3,860.00	\$0.00	\$0.00	\$0.00
ENERGY3	Energy	\$3,534.08	\$0.00	\$0.00	\$0.00
ENERGY4	Energy	\$2,464.11	-\$309.71	\$0.00	\$0.00
DIR.	HD	\$2,009.60	\$0.00	\$0.00	\$2,009.60
TOTAL		\$55,330.63	-\$1,094.15	\$0.00	\$2,009.60
COUNCIL					
CC1		\$0.00	\$0.00	\$0.00	\$0.00
CC5		\$0.00	\$0.00	\$0.00	\$0.00
CC6		\$0.00	\$0.00	\$0.00	\$0.00
CC7		\$0.00	\$0.00	\$0.00	\$0.00
CC9		\$0.00	\$0.00	\$0.00	\$0.00
CC10		\$0.00	\$0.00	\$0.00	\$0.00
TOTAL		\$0.00	\$0.00	\$0.00	\$0.00
PART-TIME					
MGR.	HHD	\$223.30	\$0.00	\$0.00	\$223.30
EW	Office	\$0.00	\$0.00	\$0.00	\$0.00
DPW	DPW-PT	\$0.00	\$0.00	\$0.00	\$0.00
PPO	POL-PT	\$165.00	\$0.00	\$0.00	\$165.00
PPO	POL-PT	\$450.00	\$0.00	\$0.00	\$450.00
PPO	POL-PT	\$900.00	\$0.00	\$0.00	\$900.00
PPO	POL-PT	\$0.00	\$0.00	\$0.00	\$0.00
TOTAL		\$1,738.30	\$0.00	\$0.00	\$1,738.30
TOTAL PAYROLL		\$57,068.93	-\$1,094.15	\$0.00	\$3,747.90

For Payroll ID: 114

For Selected Pay Code(s): 15X, 225X, 2X

Pay Code ID	Distribution	Sup Hours	Reg Hours	Reg Gross	Ot Hours	OT Gross	Gross
32DPW	- ADAMS, MATTHEW T						
	Employee Totals:	0.00	0.00	0.00	4.00	176.54	176.54
46DPW	- LLOYD, FRANKLIN J						
	Employee Totals:	0.00	0.00	0.00	4.00	173.07	173.07
113HPD	- MANTYCK, ELIZABETH A						
	Employee Totals:	0.00	0.00	0.00	11.00	434.83	434.83
25HYD	- VAN ZOEREN, ANDREW						
	Employee Totals:	0.00	0.00	0.00	6.25	309.71	309.71
Distribution Totals:							
	101-301.000-702.900	0.00	0.00	0.00	11.00	434.83	434.83
	202-478.000-702.900	0.00	0.00	0.00	2.00	100.88	100.88
	203-478.000-702.900	0.00	0.00	0.00	2.00	75.66	75.66
	590-527.100-702.900	0.00	0.00	0.00	10.25	482.78	482.78
	Grand Totals:	0.00	0.00	0.00	25.25	1,094.15	1,094.15



CITY OF HART

407 S. STATE ST.

HART, MI 49420

Hart Economic and Redevelopment Team (H.E.A.R.T.)

December 16, 2020

MINUTES – DRAFT

1) Call to Order

President Splane called the meeting to order at 4:00 pm. Rollcall was then taken.

2) Roll Call

Members present via Zoom: Rob Splane, Scott Beal, Vicki Platt, Brandon Bruce and Tracey Lipps

Members absent: Jake Tufts, Brandi Bruch

Others present: Economic Development Director Nichole Steel, Braxton Platt

3) Public Comments

Mayor Platt stated that she will be resigning from the board and appointing Councilmember Braxton Platt to take her place.

4) Action Items

a) **Approval of the November 18, 2020, regular meeting minutes** - Beal moved to approve the minutes as written, supported by Bruce, all ayes, motion carried.

b) **Financials** - Bruce moved to approve the financials as submitted, supported by Platt, all ayes, motion carried.

c) **Music on the Commons funding request to city council** – Steel provided last year’s band lineup showing that \$6,000 was spent on 7 bands (7 weeks of performances) asking if the board would like to request the same amount from city council for 2021. Platt asked if it was possible to seek sponsorships, Lipps stated that West Shore Bank has been a sponsor in the past. Platt mentioned Gayles Agency, Peterson Farms & Inspire as possibilities. Platt would like to see the MCACA grant submitted by January 15th. Splane cautioned that having a plan in place before reaching out to sponsors is encouraged to avoid duplicate asks and a professional approach. GHSP is another possibility. Steel agreed to prepare a sponsorship request form – board supported. Splane also wondered if asking a local venue to pay for band in return for having them perform at their location after should be explored. The historic district’s performances were mentioned by Platt, Ladner cautioned this partnership stating that the district sends bills after the fact and may not be the best example of fundraising. Platt concluded that Tracey will complete the MCACA grant, Nichole will complete the sponsorship request form. Steel suggested fundraising in January to & asking for the remainder from council in February. Lipps expressed concern over losing the bands if we wait until February to book. Steel suggested a sub-committee to bring these decisions to vote in leu of time left for other agenda items. Splane clarified that HEART’s available funds & suggested that instead of taking this request to council in February, we fund as a board. Motion to take request to council, seconded by Platt was rescinded.

d) **HEART Board of Director Positions & Bylaw Reviews** – Steel shared that we are currently operating with 6 active board members, HEART bylaws require a minimum of 7, maximum of 11. Steel asked if the board would like to recruit new members. Splane thought serving on the board might be too much to ask, he suggested recruiting “committee members” instead, requiring each active board member to chair a HEART committee. Steel asked the board to clarify the number of directors it would like. Splane requested this item be tabled until the next meeting when we know which council member members will be appointed and know better what Bruch will do. Steel suggested HEART consider hosting an annual meeting in accordance with its bylaws to honor

incoming/outgoing board members, business of the year and possibly other categories during a meal/receptions.

Motion by Lipps to motion item 4d, supported by Splane, all ayes. Motion carries.

5) Executive Director's Report

Events

- 12.05.20 | Thrift & Gift Crawl @ 6 stops in Hart encouraging local shopping, Steel shared results
- 12.14.20 | *NEW - Letters to Santa mailbox at Hart Commons
- Holiday Home & Business Decorating Contest –Light tour map & online photos of participants available on social media and HEART's website for public voting. Participating locations have a yard sign - winners will be announced the last week of December. Platt asked that we share photos of participants on our websites. Splane added that two groups will be caroling in conjunction with this event.

Updates

- Pure Michigan announced another Small Business Relief initiative to provide grants up to \$15,000 for Covid recovery. Applications opened December 15th on a first-in, first-served basis.
- Hart Signage, Display Boards and branding #takemetohart (ongoing)
- Hart Economic Development website (ongoing).
- Heggs TIFA Façade Improvement Grant has been completed.

Action Items

- Work with the Discover Oceana team to get "check here first" in windows of businesses

6) Updates/Discussion Items

a) Economic Development Committee Updates – Steel asked the board for direction on reforming our strategic committees to best help us achieve our objectives for the following categories. Splane suggested that goal-setting should be a homework assignment. Splane would like to see our 2020 recap in the form of a press release in January.

- i) Education** – Steel advised that instead of trying to solve our education strategic objectives with a HEART committee of three, she and will be joining the existing Oceana College Access Leadership Team monthly meeting and that her and B. Bruce have formed an action team to pursue a college extension office and career/tech center in Hart.
- ii) Destination & Marketing** – Steel shared an overview of this committee's progress and to include that a shared service event coordinator between the Chamber and City of Hart is being discussed with a goal of having this position in place by March. Lipps would like to join this discussion.
- iii) Industry Activities** – Has not met, only one committee member since Ladner left. Splane will email suggestions.
- iv) Regional Collaboration** – no suggested committee members, will rely on current committee and Discover Oceana team
- v) Infrastructure** – Committee is currently Platt & Lipps. Platt is resigning, Lipps stated this committee is not the best fit for her. Splane suggested inviting Mike Shiller, Platt suggested Jason Gayle who she can connect us with, Splane added Linda Kenosian who is retired from Great Lakes Energy.

7) Development Leads – Steel shared leads spreadsheet and asked board to help with any connections they may have to help find locations for our lead inquiries. Splane shared that the GM at the Ceres building shared that the co-op is very community minded and would be willing to discuss options. Splane would like to see a proactive approach to finding a good fit for this property, Steel will submit specs to MEDC to get property posted on

- 8) **Board Member Comments** – Platt would like to see board member applications available online and on Facebook asking for submissions to be sent directly to Nichole.
- 9) **Adjournment** - Platt made a motion to adjourn the meeting at 5:07 pm, supported by Beal, all ayes, the motion carried. Meeting adjourned.

The next regularly scheduled meeting is on Wednesday, January 20, 2021, at 4:00 pm.

Respectfully Submitted,



Economic & Community Development Director
City of Hart

City Of Hart

407 S. State St

Hart, Mi 49420

Planning Commission

Thursday, December 3, 2020

Minutes

MEMBERS PRESENT: Betty Root, Gale Goldberg, Jim Cunningham, and Rob Splane

ABSENT: Diane LaPorte, Peggy Wittman, Jack Wittman

OTHERS PRESENT: Lynne Ladner (City Manager), and Karla Swihart (Dep. Clerk), David Jirousek (Horizon Community), Vicki Platt (City Mayor) , Larry Doran (La Fiesta Chip)

B. Root called the meeting to order at 4 pm.

A motion was made by J. Cunningham to approve the agenda and supported by R. Splane
Ayes 4 Nays 0 Absent 3. The motion carried.

A motion to adopt the Nov. 5th, 2020, meeting minutes by R. Splane and supported by J. Cunningham
Ayes 4 Nays 0 Absent 3. The motion carried.

PUBLIC COMMENTS, CORRESPONDENCE, EVENTS, PRESENTATIONS: None

ACTION ITEMS: None

DISCUSSION ITEMS:

A. Presentation regarding potential request for Conditional Rezoning for S. State St.

L. Doran presented, Proposal 710 S. State St

La Fiesta Chips has grown 40% every year and running out of room. La Fiesta Chip is interested in purchasing 710 S. State St to manufacture their chips and run some disturbing. Down the road would like to start making the tortilla chips as well. There would be some delivery trucks coming in and out.

As of this point, nothing is set in stone as we would like to know the Planning Commission would consider/approve a rezoning before we move forward with any plans.

Also note we are a one shift company hours 6:00 am-5:30 pm.

R. Splane stated rezoning to a B-2 would run into issues with a small industrial. Would La. Fiesta Chip entertain a retail storefront for rental?

L. Doran, I would have to take this to the group for discussion.

L. Doran also stated there would be updates done to the building, both exterior and interior, and landscaping. The group takes pride in what they do and like to have things in tip-top shape and looking nice.

Doran asked what The Planning Commission's primary concern or biggest hurdle is.

R. Splane stated consistency and future land use?

L. Doran asked for a list of concerns to take them back to the group and get answers back to The Planning Commission before the next meeting.

OTHER BUSINESS AND COMMUNICATIONS FROM THE COMMISSION MEMBERS: None

A motion was made by R. Splane to adjourn the meeting and supported by J. Cunningham
All ayes, Nays 0, Absent 3. The motion was carried, and the meeting was adjourned at 4:44 pm

The next scheduled meeting is on January 7th, 2021



CITY OF HART

407 S. STATE ST.

HART, MI 49420

TAX INCREMENT FINANCE AUTHORITY (TIFA)

November 12, 2020, at 1:00 pm

INFORMATIONAL MEETING

MINUTES – DRAFT

Members Present via Zoom or in-person: Steve Bruch, Tracey Lipps.

Members absent: Scott Hegg, Bill Hegg, Lynne Ladner, Gale Goldberg

Others present: HEART Director – Nichole Steel

Ms. Steel narrated a PowerPoint presentation showing the projects and accomplishments that the TIFA program has afforded the City of Hart.

The next regularly scheduled meeting will be on December 10, 2020, at 1:00 pm.

Respectfully submitted,

Cheri Eisenlohr
Deputy City Clerk



DIRECTOR'S REPORT

Jan 22, 2021

Events

- 2021 Hart Winterfest Vintage Snowmobile Show @ fairgrounds on Feb 6th (pending approval frp, City Council)

Updates

- Serving on local review committee to represent Hart businesses for the allocation of MI Small Biz Survival Grant funding for our county. Funds will be issued by Feb 28th.
- Applied for \$4000 MCACA Mini Grant to offset cost of bands, submitted 01/16/21
- Prepared Music on Commons Sponsorship Request form
- Downtown Banners arrived and will be hung as DPW has time.
- Nicole Russell, Assistant GM of Big Hart Brewing Co will join the HEART board in Feb 2021
- New Hart Economic Development website will go live this month.
- Attending weekly MEDC Economic Development enrichment courses.
- EDUCATION - working on bring a Resource Center to Hart with college satellite classes, MI Works!, United Way, potentially trade/tech classes, etc.
- INFRASTRUCTURE – working to address downtown trees & streetscapes and applying for Wastewater Infrastructure Improvement EDC Grant
- INDUSTRY ACTIVITIES – plans to build a business retention team, turn HEART office into a professional business resource center & create a Relocation Guide
- MARKETING – getting quotes on what new wayfinding signage (to lead guests to our attractions) would cost, working w/ visitors bureau on a shared service event coordinator, building inventory of business resource handouts including available properties in Hart.
- 3 business & employee grant opportunities launched this week.
- Music on Commons lineup set for 2021 – we have expanded the # of concerts to offer a performance every week in the summer (instead of every other week)
- Next Regular HEART Meeting February 17, 2021 @ 4 PM

Respectfully Submitted,

Nichole Steel

Economic & Community Development Director





City of Hart Police Department

407 State Street

Ph. (231)873-2488 Fax (231)873-0100

Hart, MI 49420-1259

Juan Salazar, Chief

TO: City of Hart Mayor, City Council, and City Manager
FROM: Juan Salazar, Chief of Police
DATE: January 26th, 2021

RECENT EVENTS

From Tuesday, January 7th, 2021, through Wednesday, January 20th, 2021, the Hart Police Department received 74 complaints ranging from Personal Protection Order Violations, Civil Matters, Possession of Marijuana by a Juvenile, Property Damage Crashes, Vehicle Violations, Assist to Other Agencies, Animal Complaints, Domestic Assaults, Harassment Complaints, Assault & Batteries, Suspicious Situations, Disturbances, Medical Assists, Larcenies, Alarms, Well-Being Checks and Motorist Assists.

On Friday, January 8th, 2021, the Hart Police Department was dispatched to the 300 block of Johnson Street, referencing a 12-year-old female child possessing a leafy green substance within her backpack. The child was interviewed in front of her parents and admitted she had accidentally placed this leafy green substance within her backpack. The leafy green substance was field tested and tested positive for Marijuana. A report will be submitted to the Oceana County Prosecutor's Office.

On Saturday, January 9th, 2021, the Hart Police Department initiated a traffic stop on a vehicle on State Street near Lincoln Street regarding a vehicle violation. A 58-year-old Walkerville man was cited for Operating a Motor Vehicle without Insurance.

On Saturday, January 9th, 2021, the Hart Police Department was dispatched to the 400 block of Wood Street about a Hit & Run Crash. The responding officer received information of a 58-year-old Hart man who had backed his vehicle into a legally parked / unoccupied vehicle, which belonged to an 18-year-old Hart woman, causing damage. The man left the scene without reporting the crash to law enforcement. The man was located and interviewed and later admitted he had collided with a vehicle while backing out of a parking spot. It should be noted; the man was highly intoxicated at the time of his interview. A report will be submitted to the Oceana County Prosecutor's Office to reference this man leaving the scene of a crash and operating a motor vehicle without a license.

On Monday, January 11th, 2021, the Hart Police Department was dispatched to the 200 block of Griswold Street referencing a Domestic Assault. A 52-year-old Hart woman and a 44-year-old Hart man were in an argument, and during the argument, the man had pushed/shoved the woman. The woman fell, striking her head on a chest within the room. The man left before the officers arrival. The man also had taken, without the woman's permission, her cellular telephone from the home. A report will be submitted to the Oceana County Prosecutor's Office.

On Tuesday, January 12th, 2021, the Hart Police Department was dispatched to the 10 block of State Street about a Disturbance, which was reported to involve a firearm. A 56-year-old Hart man stated a 28-year-old Hart man had assaulted him. The 56-year-old Hart man had made several threats to officers of owning a firearm and "dealing with it himself." The 28-year-old man stated he had been continually harassed by the 56-year-old Hart man and had been assaulted by the man by being pushed/shoved on the mentioned date. A report will be submitted to the Oceana County Prosecutor's Office.

On Thursday, January 14th, 2021, the Hart Police Department initiated a traffic stop on a vehicle on West Main Street near Courtland Street regarding an equipment violation. A 23-year-old Muskegon Heights man was cited for Driving While License Suspended.

On Thursday, January 14th, 2021, the Hart Police Department was dispatched to the area of Polk Road near 72nd Avenue referencing a Property Injury Crash involving three (3) vehicles. It was reported, a 40-year-old Hart man who was traveling Westbound on Polk Road. A 29-year-old Hart woman was traveling Eastbound on Polk Road. The 29-year-old Hart woman turned directly in front of the man attempting to turn Northbound on 72nd Avenue, causing a collision. A 40-year-old Hart woman then rear-ended the 29-year-old Hart woman's vehicle. The man and 40-year-old Hart woman sustained injuries from this crash and were transported to Mercy Health Hospital in Muskegon for their injuries. The 29-year-old Hart woman was arrested and lodged at the Oceana County Jail for Operating While Intoxicated (Alcohol) 2nd or Subsequent Offence. The 29-year-old Hart woman was later charged with Operating While Intoxicated Causing Serious Injury. The department was assisted by the Michigan State Police, Oceana County Sheriff's Office, LIFE EMS and the Hart Fire Department.

On Friday, January 15th, 2021, the Hart Police Department was dispatched to the 600 block of Griswold Street about a Domestic Assault. A 41-year-old Hart woman claims to have been assaulted by being shoved by a 41-year-old Hart man. Parties were interviewed and separated for the remainder of the day. A report will be submitted to the Ocean County Prosecutor's Office.

On Sunday, January 17th, 2021, the Hart Police Department was dispatched to the 400 block of Washington Street, referencing an individual looking into a residence window. A 28-year-old Hart man was interviewed regarding this complaint. The man admitted to being under the influence of illegal drugs. The man showed multiple warrants for his arrest, but due to COVID19 restrictions, the man could not be arrested on these warrants. A report will be submitted to the Oceana County Prosecutor's Office.

Respectfully,

J. Salazar,
Chief of Police

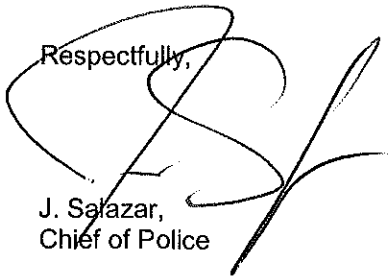



CITY OF HART
 407 S. State St., Hart, MI 49420
 Ph: 231-873-2488 Fax: 231-873-0100
SPECIAL EVENTS PERMIT



THE CITY IS NOT RESPONSIBLE FOR BY-STANDERS AT YOUR EVENT.

DATE OF APPLICATION: 01/22/2021

NAME OF EVENT: HART WINTERFEST VINTAGE SNOWMOBILE SHOW & SWAP MEET

DATE OF EVENT: 02/06/2021 TIME: 10:00 AM TO 2:00 PM

RAIN DATE OF EVENT: **MUST PROVIDE** NO RAIN DATE

LOCATION AND/OR ROUTE OF EVENT:

OCEANA COUNTY FAIRGROUNDS, 1025 S STATE ST, HART, MI

DESCRIPTION OF EVENT:

Vintage snowmobile show & swap meet open to public, guests required to wear masks & practice social distancing

SPECIAL NEEDS:

no special needs from City of Hart

NAME OF ORGANIZATION OR SPONSOR: OCEANA COUNTY FAIRGROUNDS

ADDRESS: 1025 S STATE ST, HART, MI

CONTACT PERSON: KEVIN HALLACK

PHONE: 231-923-9279 FAX:

EMAIL: kmhallac@gmail.com

x *Kevin Hallack*

SIGNATURE OF EVENT COORDINATOR/SPONSOR

DATE 01/22/2021

**IT IS YOUR RESPONSIBILITY TO SCHEDULE THE LOGISTICS MEETING WITH THE CITY DEPARTMENTS INDICATED
 IF YOUR APPROVED PERMIT INDICATES THAT A MEETING IS NEEDED. PLEASE NOTE THAT A 7 - 10 DAY
 ADVANCE NOTICE WILL BE NEEDED TO SCHEDULE THE MEETING.
 POLICE: 873-2488, DPW: 873-3100, HYDRO: 873-5367, EMS: 873-8240**

SECTIONS BELOW TO BE COMPLETED BY THE CITY

PROOF OF LIABILITY INSURANCE FOR STREET SOLICITATION: YES OR NO

LOGISTICS MEETING NEEDED: YES OR NO

DEPT. ATTENDING: DPW POLICE EMS HYDRO

PERMIT NUMBER: APPROVED BY CITY COUNCIL/CITY MANAGER

DATE OF APPROVAL/DENIAL: YES OR NO

CONDITIONS:

CITY REPRESENTATIVE'S SIGNATURE:



CITY OF HART
 407 S. State St., Hart, MI 49420
 Ph: 231-873-2488 Fax: 231-873-0100
SPECIAL EVENTS PERMIT



THE CITY IS NOT RESPONSIBLE FOR BY-STANDERS AT YOUR EVENT.

DATE OF APPLICATION: 01/22/2021

NAME OF EVENT: 2021 Music on the Commons | Summer Concert Series

DATE OF EVENT: Thursdays Jun 17-Aug 26 TIME: 7:00 PM TO 9:00 PM

RAIN DATE OF EVENT: **MUST PROVIDE** if indoor gatherings are allowed - Historic District, otherwise cancelled

LOCATION AND/OR ROUTE OF EVENT:

Hart Commons Park

DESCRIPTION OF EVENT:

Free weekly outdoor musical performances open to public, variety of genres

SPECIAL NEEDS:

use of Hart Commons from 4-9p (dates above), help from DPW if fencing is required

NAME OF ORGANIZATION OR SPONSOR: Hart Economic & Redevelopment Team

ADDRESS: 49 S State St, Hart, MI

CONTACT PERSON: Nichole Steel

PHONE: 231-301-8449

FAX:

EMAIL: nsteel@cityofhart.org

x *Nichole Steel*

SIGNATURE OF EVENT COORDINATOR/SPONSOR

DATE 01/22/2021

IT IS YOUR RESPONSIBILITY TO SCHEDULE THE LOGISTICS MEETING WITH THE CITY DEPARTMENTS INDICATED IF YOUR APPROVED PERMIT INDICATES THAT A MEETING IS NEEDED. PLEASE NOTE THAT A 7 - 10 DAY ADVANCE NOTICE WILL BE NEEDED TO SCHEDULE THE MEETING.
POLICE: 873-2488, DPW: 873-3100, HYDRO: 873-5367, EMS: 873-8240

SECTIONS BELOW TO BE COMPLETED BY THE CITY

PROOF OF LIABILITY INSURANCE FOR STREET SOLICITATION: YES OR NO

LOGISTICS MEETING NEEDED: YES OR NO

DEPT. ATTENDING: DPW POLICE EMS HYDRO

PERMIT NUMBER: _____ APPROVED BY CITY COUNCIL/CITY MANAGER

DATE OF APPROVAL/DENIAL: YES OR NO

CONDITIONS:

CITY REPRESENTATIVE'S SIGNATURE:

Memo

To: Mayor and Council
From: Lynne Ladner
Date: 1/22/2021
Re: Resolution 2021-02 Sackrider Church roof bids

Ladies and Gentlemen,

In early fall 2020 the Council accepted bids for the replacement of the Sackrider Church Roof and awarded the contract. However, once the company was contacted regarding the award the City was informed that the bid had expired and due to increase materials cost they could not complete the project for the price bid.

The Historic District has rebid the project (and I have verified all bids are current and active) as the project still needs to be completed. The new bids are as follows: Sam Near Roofing LLC (Shelby, MI) in the amount of \$19,535, from Juan Time Roofing (Shelby, MI) in the amount of \$18,900 for a shingle roof and Janet's Roofing (Shelby, MI) in the amount of \$20,500. The low bid is Juan Time Roofing in the amount of \$18,900 and they are able to complete the job in late February/early March.

It is my recommendation that the council adopt Resolution 2021-02 Accepting Bids for the roof replacement on the Sackrider Church and award the contract to Juan Time Roofing in the amount of \$18,900 to be completed in late February/early March and authorize the City Manager to sign all necessary paperwork.

Lynne

City Manager
City of Hart

Enclosed are the three bids for the roof at the Hart Historic District Church. Two bids they can't do it until June or July. Juan Time Roofing can do it in Feb or March. We need it put on as soon as possible, as we do not want any leaks into the church.

Juan Time Roofing= \$18,900

Sam Near Roofing= \$19,535

Janets Roofing= \$20,500

They all require 50% down

Thank you,

Leigh Furgason, Pres

Feb or March

1-231-742-1540

Juan Time Roofing Repair

Customer Name: Leigha Furgason

Date: January 12, 2021

Bid for work at: 570 E Lincoln St. Hart, MI 49420

Bid # 1002021

Telephone Number:

Email:

Bid includes material and labor. We will take the proper steps to ensure that all garden and landscaping items are protected.

1. Tear off existing shingles. I will inspect roof for any damages and/or needed repairs. (I will notify customer if any major repairs are necessary.)
2. Open two inches at peak in order to create ventilation
3. We will apply 1.5 inch Drip Edge
4. Next, we will apply 6 ft of Winterguard Alcho Ice and Water shield at eaves.
5. We will apply Rhino synthetic felt
6. Last step will be to install Landmark Pro shingles in the color chosen by customer. Shingles will also be applied on tower.

Total Roofing Project Cost: \$18,900

- * We will clean surrounding work area making sure area is free of any old roofing debris.
- * JTRR will provide dumpster to get rid of any trash that is accumulated during the roofing process

Comments or special instructions:

Half down due upon acceptance of bid. Balance due upon job completion.

Customer Signature Leigha Furgason, Pres. Hart Historic District

Juan Rodriguez Signature _____

Shingle Color Chosen _____

**Not Responsible for ice and/or severe weather damage.*

All work done by Juan Time Roofing Repair has a 5-year guarantee.

Questions? Contact Juan Rodriguez at (231) 742-1540 or at juantimerootingrepair@gmail.com

Thank You for Your Business!

231-690-1556 Janet

June
14, 200
1/17/2021

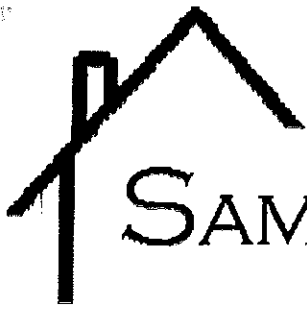

SAM NEAR ROOFING LLC

address { 1625 W Woodrow Rd
Shelby MI 49455-9499

231-861-2537

SNROOFING@GMAIL.COM

This quote specially prepared for:
HART HISTORIC DISTRICT
570 E LINCOLN ST, HART, MI 49420

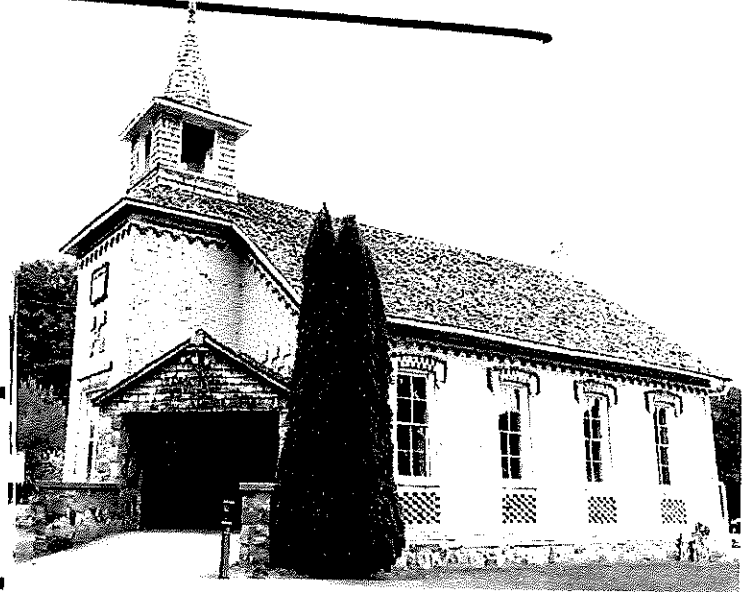

We are fully licensed and insured. Others may not be. Certificates available.

ROOFING it's all we do and all we've ever done. We're experienced and pay attention to details. We're here.

23 YEARS!
1998-2021

Your Warranty

We warrant our work against leaks and wind damage for five (5) years. If anything happens, we're coming back to fix it.

*NOTE: We do not warrant your roof to be free from leaks caused by **ice dams**. Ice dams need removed when 6" thick.*

we use a premium brand of ice & water barrier

called **Weatherlock Flex®**

because it's the best to help protect your roof against leaks

Hope we can help with your roof!



1625 W Woodrow Rd
Shelby, MI 49455
231-861-2537

23 YEARS!
1998-2021

JOB PROPOSAL

1/17/2021

HART HISTORIC DISTRICT	CHURCH ROOF – SHINGLE	5345
570 E LINCOLN ST		
HART, MI 49420	LEIGH FERGUSON 231-869-2042	

Estimate to install new shingle roof on church:

Summary: This proposal is for installation of a new shingle roof on church, including lower roofs above North & South entrances. Separate pricing for bell tower due to options below. We want our new roof to last 30 years using the following methods honed over the past 23 years. **There are 2 pages to this proposal (front & rear); please read both carefully.**

Tear Off & Disposal: Remove one (1) layer existing roof material. Cleanup & disposal included. Protect gutters, walls, windows & landscape as needed. Access roof with 7' wide motorized dump cart to collect debris at eaves. Minor repair of rotten wood deck included. Run magnetic sweeper across drive & lawn for nails when finished.

If Sheathing is Needed: If old roof boards present, install new 7/16" OSB sheathing (including North & South entrances), otherwise life of shingle roof greatly reduced. Cost of sheathing is triple from a year ago due to supply shortages.

Underlayment: Apply a mid-grade ice & water barrier 3' at eaves (adequate). Apply our best ice & water barrier (Weatherlock Flex) at the following critical locations: 1.5' at brick walls & chimney. For remainder of roof surface, apply Shingle Mate fiberglass felt (prevents wrinkles). At roof perimeter, install 1 1/2" WHITE drip edge.

Installation: Install Timberline shingles, in a color chosen by customer. At peaks, install matching cap shingles.

Ridge Vent: We can install ridge vent on main peak for additional \$500 (cut 1 1/2" slot) but there will be little benefit due to insulation blockage and lack of soffit ventilation at eaves.

*Continued
on reverse* →

HART HISTORIC DISTRICT CHURCH 5345

Installation (cont):

Brick Walls & Chimney: No cost difference to remove chimney to roofline if unused (cover hole). At walls & chimney, apply our best ice & water 4" up sides to seal. Use painted aluminum step flashing and cover with counter flashing. At gully on left side of South entrance roof, it is recommended we build up slightly so water doesn't flow against wall, OR install EPDM rubber membrane in area (no additional cost).

Bell Tower: We will rent a boom lift to access top of bell tower (an \$1,850 value). We can install shingles on vertical walls (\$850 additional cost), but it is recommended to install proper siding since asphalt shingles will slide down (even with our additional fastening and dabs of tar). We don't do siding.

Furthermore, it would make sense to install a longer-lasting roof such as Standing Seam metal (concealed fasteners; additional cost \$1,820) due to costliest part being access. If customer desires to perform other work on bell tower at same time, it makes sense customer would rent boom lift.

Sam Near Roofing LLC to furnish all labor & material for this proposed roof job for the sum of:

Payment: Half due at signing; balance due when job is complete <i>Thank You</i>	INSTALL NEW SHINGLE ROOF	\$10,780
	IF SHEATHING IS NEEDED	\$5,275
	BELL TOWER – SHINGLES	\$3,480
	INCLUDES LIFT + OSB SHEATHING	

Proposal void after 30 days

SNR Authorized Signature Laurence Near

Date 1/17/21

Customer signature _____

Date _____

Customer signature _____

Date _____

Shingle Color Desired: _____



ESTIMATE: # 1082
 DATE: 08/11/2020

Diaz Construction
 204 N. State St.
 Shelby, MI 49455 US
 luis.diazconstruction@gmail.com

Janet Swanson
 252 E Johnson
 Shelby, Mi 49455
 Phone & Fax: 231-861-0397
 Cell: 231-690-1556

SERVICE

Shingles

DESCRIPTION	QTY	RATE	AMOUNT
I propose to supply all materials tools and labor to install a new roof system. Product quoted Certaineed Landmark architectural shingles Area=entire building about 2500 sq. ft. *I'm going to tear off existing roof material down to roof deck, inspect for wood damage **NOTE (this estimate does not include wood repair, any wood repair will be \$70.00 per 1/2 inch OSB) *Install Certaineed winter guard ice and water shield all eaves, valleys and roof penetrations * installing synthetic underlayment remaining of the roof *installing starter all eaves and gables *installing new architectural shingles * Includes new pipe boots, drip edge, flashing and ridge vent (if applicable) *remove existing corner flashing around brick chimney and install new corner flashing *installing new corner flashing on brick walls *going to remove roof material cupola roof and install new shingles NOTE** (this estimate does not include cupola walls) * Include all clean up and disposal of debris into state approved landfill	1	\$20,500	\$20,500

Total: \$20,500

Accepted By:

Accepted Date:

RESOLUTION 2021-02
Hart City Council
City of Hart, Michigan

***Accept the bids for replacement of the roof on the Sackrider Church
in the Historic District.***

WHEREAS; the City of Hart owns and maintains the Hart Historic District for the benefit of current and future generations; and,

WHEREAS; the Sackrider Church is a popular historic building in the district that is in need of ongoing maintenance which includes at this time replacement of the roof and the City has budgeted in FY 21 adequate funding for this project; and

WHEREAS; the Council had previously accepted bids for the project and awarded the project based on those bids but it was determined after the award that the bids had expired and the awarded contract was not willing to complete the project for the amount bid and accepted and

WHEREAS; the new bids have been solicited and received for the roof replacement project from Sam Near Roofing LLC (Shelby, MI) in the amount of \$19,535, from Juan Time Roofing (Shelby, MI) in the amount of \$18,900 for a shingle roof and Janet's Roofing (Shelby, MI) in the amount of \$20,500 and,

WHEREAS; due to the historic nature and design of the Sackrider Church a shingle roof replacement would be in keeping with the historic construction of the building; and

NOW THEREFORE BE IT RESOLVED THAT THE CITY COUNCIL

Accepts the bids for the replacement of the roof on the Sackrider Church, and awards the project to Juan Time Roofing (Shelby, MI) in the amount of \$19,900 and authorizes the City Manager to sign all necessary documents

Moved by _____, supported by _____ and thereafter adopted by the Hart City Council at a regular council meeting held on January 26, 2021.

Ayes: Nays: Absent:

I hereby certify this to be a true and correct copy of the document on file with the office of the City of Hart Clerk.

Cheri Eisenlohr, Dep. City Clerk

Memo

To: Mayor and Council
From: Lynne Ladner
Date: 1/22/2021
Re: Resolution 2021-03 Support for SRTS grant application

Ladies and Gentlemen,

In late 2019 I brought to the Council a resolution to support the application for the SRTS grant application in conjunction with the trail committee and the Road Commission. Unfortunately, with the challenges of COVID the project has been unable to move forward. We are now on the cusp of an application deadline for the SRTS grant program and with the hard work of the committee members, Road Commission, and City along with the collaboration of Hart Township and the Hart Cemetery board the application is in the final stages of completion for submission.

With the public hearing taking place during this meeting the last step in the application process in terms of formal action from the appropriate bodies is the passage of a resolution of support by the Council authorizing the grant application, committing funding (the City's portion of the nearly \$700,000 project is \$25,000 which comes from our required Non-Motorized Transportation funding in the Act 51 revenue sharing) from the City and the Trail Committee to fund the portion of the project covered by the grant funding of \$440,000 as well as committing to maintaining the facilities in the grant application.

It is my recommendation that the council adopt Resolution 2021-03 Supporting the SRTS grant application committing to providing in collaboration with the Pentwater-Hart Trail Committee the funds necessary to carry out the project (\$25,000 from the City of Hart, \$440,000 in grant funding and \$246,855 from the Pentwater-Hart Trail Committee funds), including engineering design and construction, permit fees, administration costs, and cost overruns; and the City commits to owning, operating, funding, and implementing a maintenance program over the design life of the facilities constructed with Safe Rotes to School funding.

Lynne

City of Hart
Safe Routes to School Project
 Engineer's Estimate of Probable Construction Cost



By: RWT, PMT
 Job No: 847680
 Date: 1/15/2021

Description: 6,135 feet of 10-ft HMA Shared Use Path along with 5-ft Sidewalk, ADA Ramps, and Restoration in the following locations:

1. Water Street from Wood Street to Johnson Street (950')
2. Johnson Street from Water Street to Peach Avenue (1400')
3. Peach Avenue from Johnson Street to Easement (200')
4. Easement from Peach Avenue to Plum Street (835')
5. Plum Street from Easement to Tyler Road (1020')
6. Tyler Road from Plum Street to 72nd Street (1170')
7. 72nd Avenue from Tyler Road to Cedar Lane (560')

Item No.	Item Description	Unit	Est Qty	Unit Price	Amount
1	Mobilization, Bonds, and Insurances, Max. 10%	LS	1	\$55,000.00	\$55,000.00
2	Erosion Control, Inlet Protection, Fabric Drop	Ea	30	\$100.00	\$3,000.00
3	Erosion Control, Silt Fence	Ft	3,000	\$2.20	\$6,600.00
4	Sidewalk, Rem	Syd	800	\$7.00	\$5,600.00
5	Drainage Improvements	LS	1	\$2,500.00	\$2,500.00
6	Retaining Wall	Sft	2,000	\$40.00	\$80,000.00
7	Embankment	Cyd	500	\$15.00	\$7,500.00
8	Detectable Warning Surface	Ft	180	\$80.00	\$14,400.00
9	Sidewalk, Conc	Sft	9,775	\$6.00	\$58,650.00
10	Shared Use Path, HMA	Ton	815	\$95.00	\$77,425.00
11	Shared Use Path, Grading	Sta	65	\$1,500.00	\$97,500.00
12	Shared Use Path, Aggregate, 6 inch	Syd	7,500	\$8.00	\$60,000.00
13	HMA Hand Patching	Ton	10	\$200.00	\$2,000.00
14	Fence, Rem	Ft	620	\$5.00	\$3,100.00
15	Fence, Chain Link, 6 foot	Ft	620	\$30.00	\$18,600.00
16	Pavement Marking	LS	1.0	\$5,000.00	\$5,000.00
17	Traffic Control, Signs, and Barricades	LS	1.0	\$15,000.00	\$15,000.00
18	Permanent Signs	LS	1.0	\$7,500.00	\$7,500.00
19	Mulch Blanket	Syd	500	\$1.50	\$750.00
20	Surface Restoration	Syd	6,000	\$3.00	\$18,000.00
21	Culvert	LS	1.0	\$5,000.00	\$5,000.00

Construction Subtotal: \$543,100.00
 Construction Contingency (10%): \$54,400.00
 Construction Total: \$597,500.00
 Design & Construction Engineering: \$99,500.00
Project Total: \$697,000.00

The Design Professional has no control over costs or the price of labor, equipment or materials, or over the Contractor's method of pricing. Bid prices may vary significantly based on these factors and market conditions at time of bid.

CITY OF HART OCEANA COUNTY, MICHIGAN IN COOPERATION WITH MICHIGAN DEPARTMENT OF TRANSPORTATION AND THE FEDERAL HIGHWAY ADMINISTRATION PLANS OF PROPOSED SAFE ROUTES TO SCHOOL

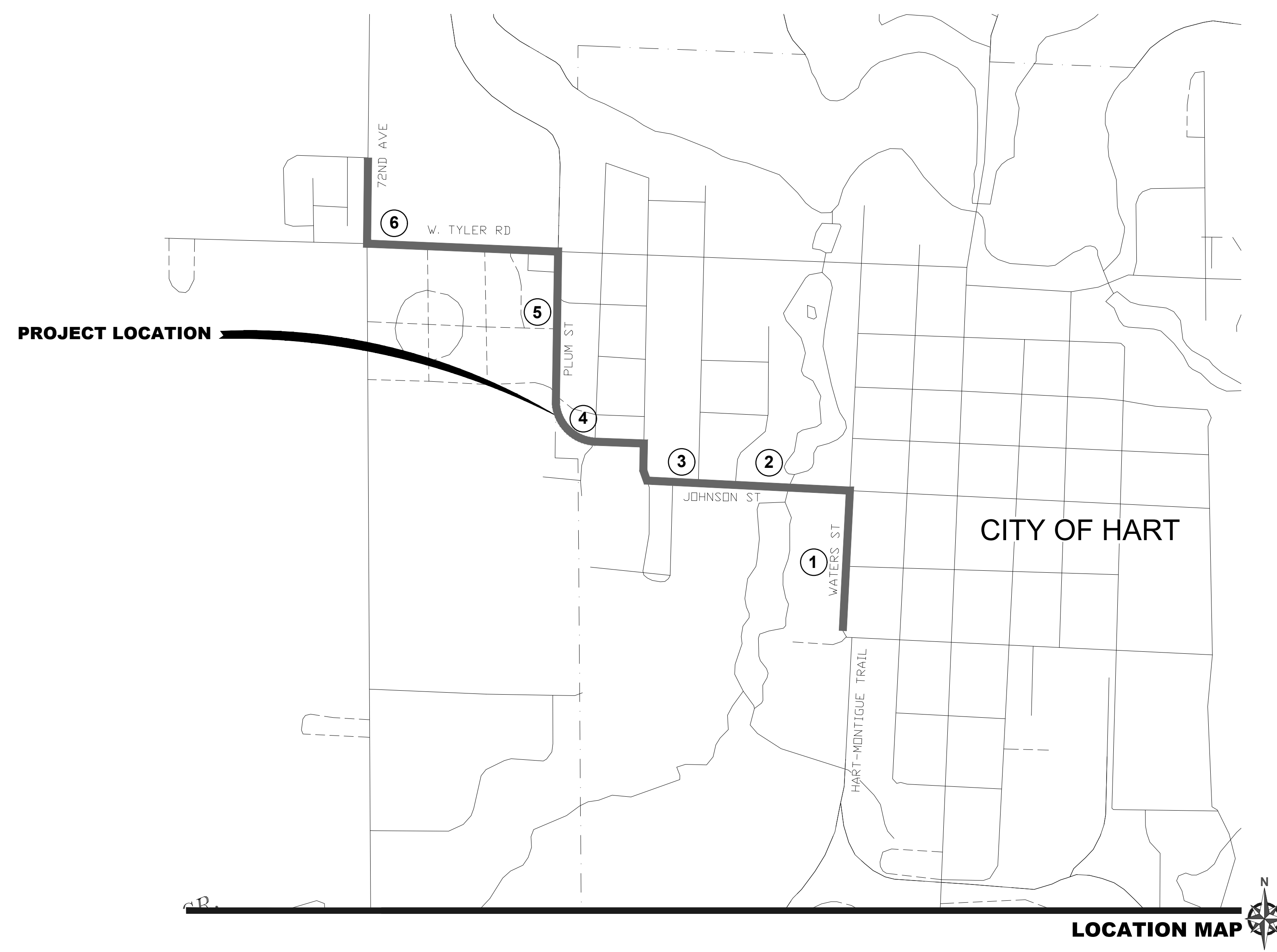
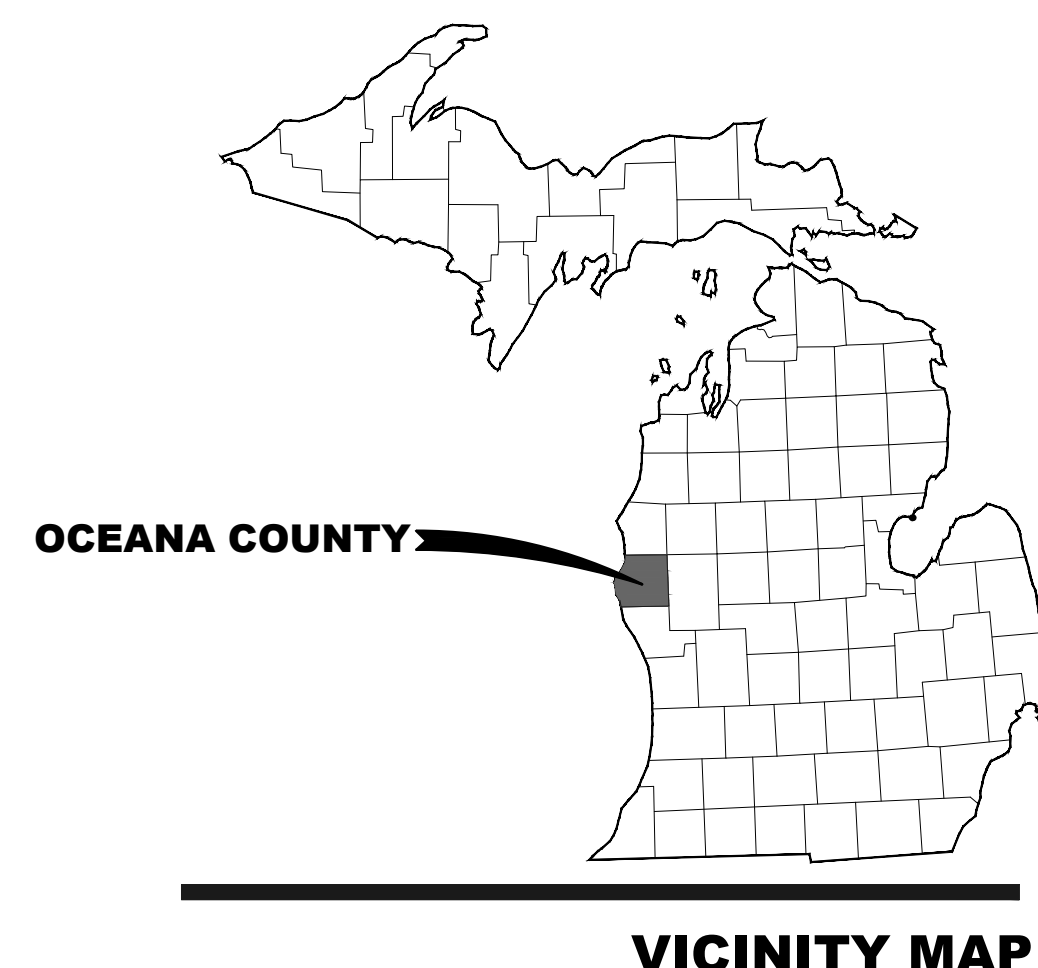

INDEX OF DRAWINGS

DESCRIPTION	SHEET NO.
COVER SHEET	G001
PLAN SHEETS	C101-C107
TYPICAL CROSS SECTIONS, DETAILS, & NOTES	C501

GENERAL NOTES

FOR PROTECTION OF UNDERGROUND UTILITIES AND IN CONFORMANCE WITH PUBLIC ACT 174 OF 2013, A CONTRACTOR SHALL PROVIDE A DIG NOTICE TO THE NOTIFICATION SYSTEM AT LEAST 72 HOURS, BUT NOT MORE THAN 14 CALENDAR DAYS, BEFORE THE START OF ANY BLASTING OR EXCAVATION. IF THE DIG NOTICE IS GIVEN DURING BUSINESS HOURS, THE 72-HOUR PERIOD SHALL BE MEASURED FROM THE TIME THE DIG NOTICE IS MADE TO THE NOTIFICATION SYSTEM. IF A DIG NOTICE IS GIVEN BEFORE 7 A.M. ON A BUSINESS DAY, THE 72-HOUR PERIOD BEGINS AT 7 A.M. ON THAT DAY. IF A DIG NOTICE IS GIVEN ON A NONBUSINESS DAY OR AFTER 5 P.M. ON A BUSINESS DAY, THE 72-HOUR PERIOD BEGINS AT 7 A.M. ON THE NEXT BUSINESS DAY. ALL HOURS OF NONBUSINESS DAYS ARE EXCLUDED IN COUNTING THE 72-HOUR PERIOD. IF THERE ARE MULTIPLE EXCAVATORS ON THE SAME SITE, EACH EXCAVATOR SHALL PROVIDE ITS OWN DIG NOTICE.

THE PLACING OF PAVEMENT MARKING AND TRAFFIC CONTROL SIGNS SHALL BE DONE IN ACCORDANCE WITH THE MICHIGAN MANUAL OF UNIFORM TRAFFIC CONTROL DEVICES, 2011 EDITION, AS AMENDED.

THE PROPOSED IMPROVEMENTS COVERED BY THESE PLANS ARE IN ACCORDANCE WITH THE AASHTO, A POLICY ON GEOMETRIC DESIGN OF HIGHWAYS AND STREETS, 2011 EDITION, AND THE AASHTO GUIDE FOR THE DEVELOPMENT OF BICYCLE FACILITIES, FOURTH EDITION.

THE IMPROVEMENTS COVERED BY THESE PLANS SHALL BE DONE IN ACCORDANCE WITH THE MICHIGAN DEPARTMENT OF TRANSPORTATION 2012 STANDARD SPECIFICATIONS FOR CONSTRUCTION AS AMENDED BY SUPPLEMENTAL SPECIFICATIONS AND SPECIAL PROVISIONS.



316 Morris Avenue, Suite 230
Muskegon, MI 49440
P: 231.726.1000
F: 231.726.2200

CITY OF HART
OCEANA COUNTY
SAFE ROUTES TO SCHOOL



Know what's below.
Call before you dig.

JANUARY 2021
FAV PROJECT NO.
847680

G001

U:\Projects\847680-848000\847680_Hart - Safe Routes to School_Application\CityPlan\847680_C101.dwg - printed on 1/12/2021 10:43 AM

HART-MONTAGUE BICYCLE TRAIL STATE PARK

EX 66' R.O.W.

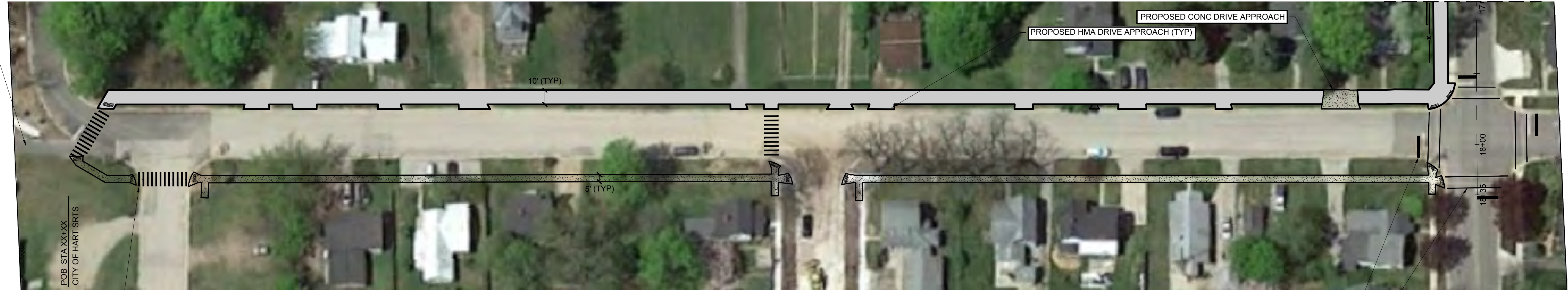

POB STA XX+XX
CITY OF HART SRTS

WOOD ST

JEFFERSON ST

JOHNSON ST

PROPOSED 12" CROSSWALK (TYP)
10' MIN

10' (TYP)

5' (TYP)

PROPOSED HMA DRIVE APPROACH (TYP)

PROPOSED CONC DRIVE APPROACH

MATCHLINE SEE SHEET C102

EX 66' R.O.W.

PROPOSED 24" STOP BAR (TYP)

PROPOSED 6" CROSSWALK (TYP)
6' MIN

EX 66' R.O.W.

HART TRAIL - WATER STREET
HMA PAVEMENT

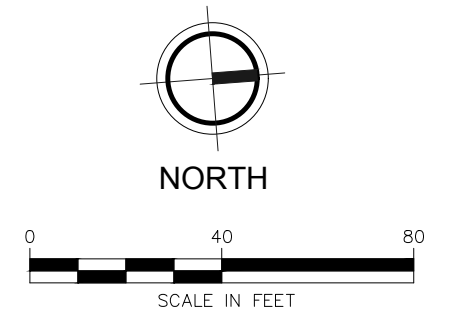

LEGEND

- PROPOSED HMA SHARED USE PATH (10' WIDE WITH 2' CLEAR LT & RT)
- PROPOSED CONC SIDEWALK / RAMP (5' WIDE ADA COMPLIANT)



316 Morris Avenue, Suite 230
Muskegon, MI 49440
P: 231.726.1000
F: 231.726.2200

REVISION:

CITY OF HART
OCEANA COUNTY
SAFE ROUTES TO SCHOOL
PROPOSED TRAIL

DESIGN TEAM:	PROJ MGR:	SRM:
	DESIGNED BY:	RWT
	DRAWN BY:	PMT
	CHECK BY:	

DRAWING INFORMATION:
847680_C101
011221.pwt

NOT FOR CONSTRUCTION

JANUARY 2021
F&V PROJECT NO.
847680



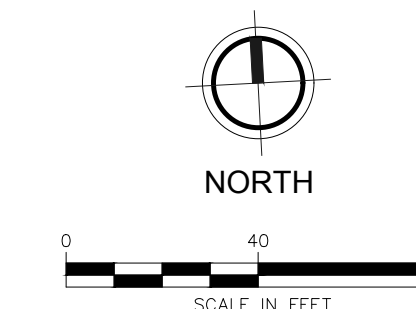

C101



HART TRAIL - JOHNSON STREET
HMA PAVEMENT

SEE SHEET C101

LEGEND

-  PROPOSED HMA SHARED USE PATH (10' WIDE WITH 2' CLEAR LT & RT)
-  PROPOSED CONC SIDEWALK / RAMP (5' WIDE ADA COMPLIANT)

DESIGN TEAM:	PROJ MGR:	SPM:
	DESIGNED BY:	RWT
	DRAWN BY:	PMT
	CHECK BY:	

DRAWING INFORMATION:
847680_C102
011121 jpat01

NOT FOR CONSTRUCTION

JANUARY 2021
F&V PROJECT NO.
847680



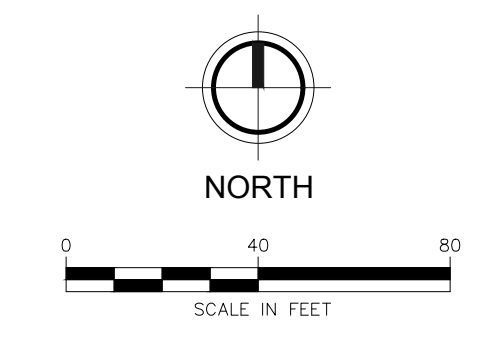

U:\Projects\847680-847680-Safe Routes to School_Application\City\Plan\847680_C102.dwg - printed on 1/12/2021 10:43 AM

U:\Projects\847680-848000\847680_Hart - Safe Routes to School_Application\CityPlan\847680_C103.dwg - printed on 1/12/2021 10:44 AM



MATCHLINE SEE SHEET C102

LEGEND

-  PROPOSED HMA SHARED USE PATH (10' WIDE WITH 2' CLEAR LT & RT)
-  PROPOSED CONC SIDEWALK / RAMP (5' WIDE ADA COMPLIANT)

NOTE: SEE SHEET D1 FOR TYPICAL CROSS SECTIONS

DESIGN TEAM:	PROJ MGR:	SPR:
	DESIGNED BY:	RWT
	DRAWN BY:	PMT
	CHECK BY:	

DRAWING INFORMATION:
 847680_C103
 011121 jpatert



NOT FOR CONSTRUCTION

JANUARY 2021
 F&V PROJECT NO.
 847680

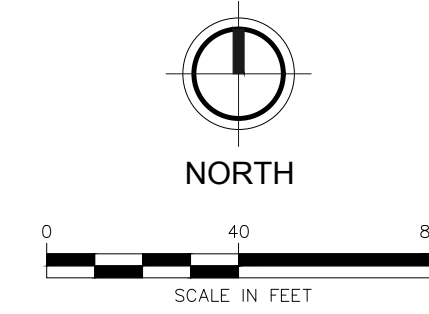



LEGEND

-  PROPOSED HMA SHARED USE PATH (10' WIDE WITH 2' CLEAR LT & RT)
-  PROPOSED CONC SIDEWALK / RAMP (5' WIDE ADA COMPLIANT)



316 Morris Avenue, Suite 230
Muskegon, MI 49440
P: 231.726.1000
F: 231.726.2200

REVISION:

CITY OF HART
OCEANA COUNTY
SAFE ROUTES TO SCHOOL
PROPOSED TRAIL

DESIGN TEAM:	PROJ MGR:	SPR:
	DESIGNED BY:	RWT
	DRAWN BY:	PM
	CHECK BY:	

DRAWING INFORMATION:
847680_C104
011121 jpatrt

NOT FOR CONSTRUCTION

JANUARY 2021
F&V PROJECT NO.
847680



Know what's below.
Call before you dig.

C104

U:\Projects\847680-848000\847680_Hart - Safe Routes to School_Application\City\Plan\847680_C104.dwg - printed on 1/12/2021 10:44 AM

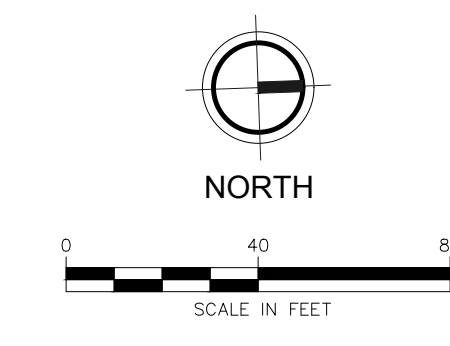

- LEGEND**
- PROPOSED HMA SHARED USE PATH (10' WIDE WITH 2' CLEAR LT & RT)
 - PROPOSED CONC SIDEWALK / RAMP (5' WIDE ADA COMPLIANT)

FLEIS & VANDENBRINK
 DESIGN. BUILD. OPERATE.
 316 Morris Avenue, Suite 230
 Muskegon, MI 49440
 P: 231.726.1000
 F: 231.726.2200

REVISION:
 CITY OF HART
 OCEANA COUNTY
 SAFE ROUTES TO SCHOOL
 PROPOSED TRAIL

DESIGN TEAM:	PROJ MGR:	SPR
	DESIGNED BY:	RWT
	DRAWN BY:	PMT
	CHECK BY:	

DRAWING INFORMATION:
 847680_C105
 011221.patrt

NOT FOR CONSTRUCTION
 JANUARY 2021
 F&V PROJECT NO.
 847680



C105

U:\Projects\847680-849000\847680_Hart - Safe Routes to School_Application\City\Print\847680_C105.dwg - printed on 1/12/2021 10:44 AM

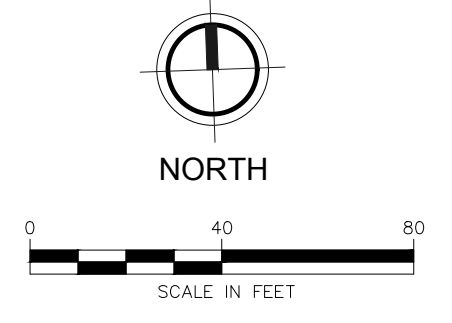

MATCHLINE SEE SHEET C107

PLUM ST

"RRFB" SIGNAL



EX. 66' R.O.W.

MATCHLINE SEE SHEET C105
EX. 60' R.O.W.

HART TRAIL - TYLER ROAD
HMA PAVEMENT

PROPOSED HMA DRIVE APPROACH (TYP.)

LEGEND

-  PROPOSED HMA SHARED USE PATH (10' WIDE WITH 2' CLEAR LT & RT)
-  PROPOSED CONC SIDEWALK / RAMP (5' WIDE ADA COMPLIANT)

REVISION:

CITY OF HART
OCEANA COUNTY
SAFE ROUTES TO SCHOOL
PROPOSED TRAIL

DESIGN TEAM:	PROJ MGR:	DATE:
	DESIGNED BY:	REV:
	DRAWN BY:	DATE:
	CHECK BY:	

DRAWING INFORMATION:
847680_C106
011221 jpt/rt

NOT FOR CONSTRUCTION

JANUARY 2021
F&V PROJECT NO.
847680



Know what's below.
Call before you dig.

C106



316 Morris Avenue, Suite 230
Muskegon, MI 49440
P: 231.726.1000
F: 231.726.2200

U:\Projects\847680-847680_Safe Routes to School_Application\CAD\Plan\847680_C106.dwg - printed on 1/22/2021 11:44 AM

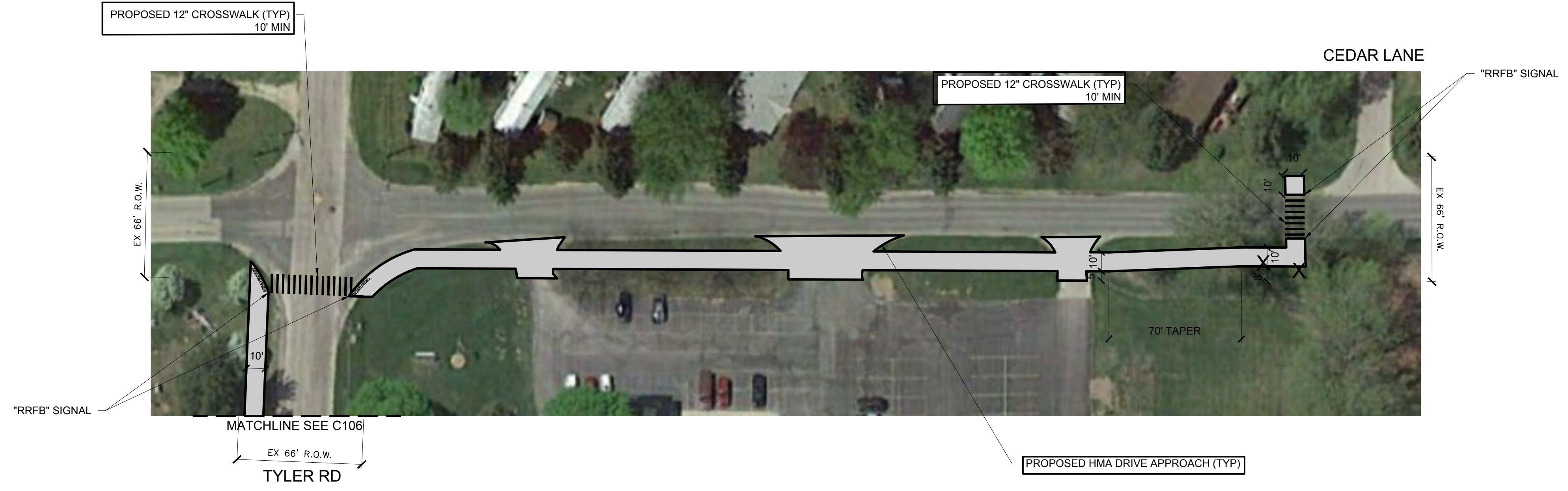
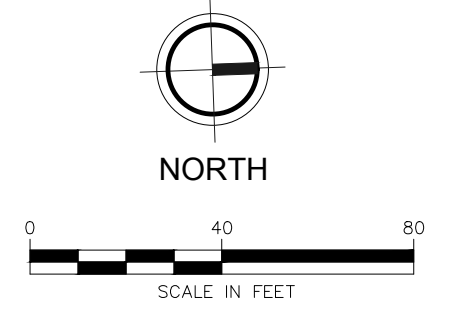

HART TRAIL - N. 72ND AVENUE
HMA PAVEMENT

LEGEND

- PROPOSED HMA SHARED USE PATH (10' WIDE WITH 2' CLEAR LT & RT)
- PROPOSED CONC SIDEWALK / RAMP (5' WIDE ADA COMPLIANT)

DESIGN TEAM:	PROJ MGR:	SRM:
	DESIGNED BY:	RWT
	DRAWN BY:	PMT
	CHECK BY:	

DRAWING INFORMATION:
847680_C107
011221.pat@rt

NOT FOR CONSTRUCTION

JANUARY 2021
F&V PROJECT NO.
847680



U:\Projects\847680-848000\847680_Hart - Safe Routes to School_Application\CAD\Plan\847680_C107.dwg - printed on 1/22/2021 11:44 AM

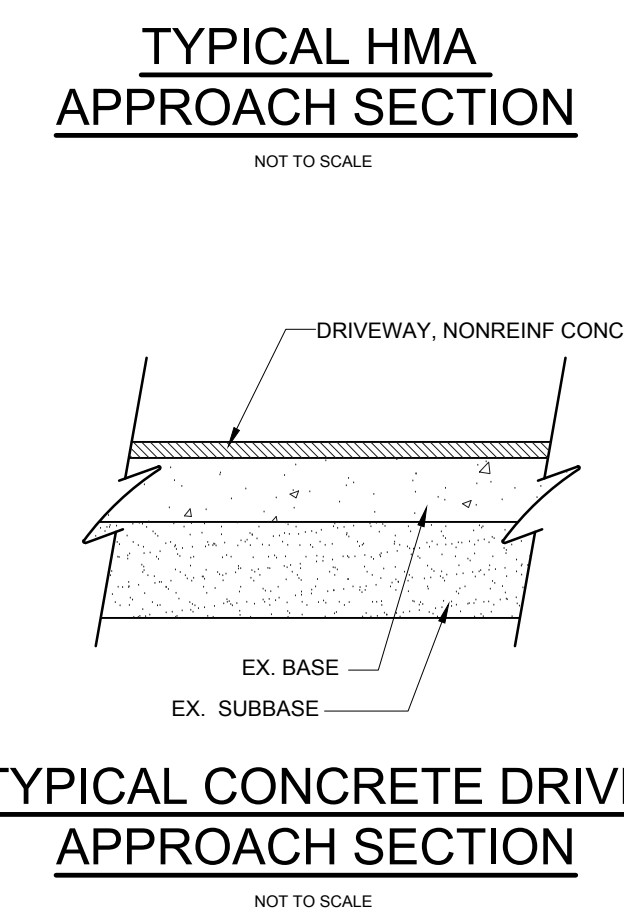
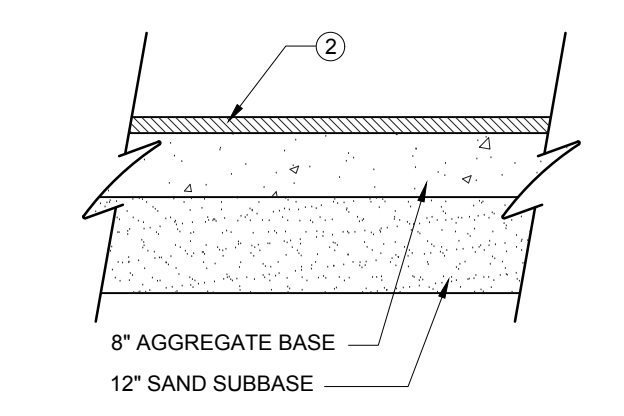
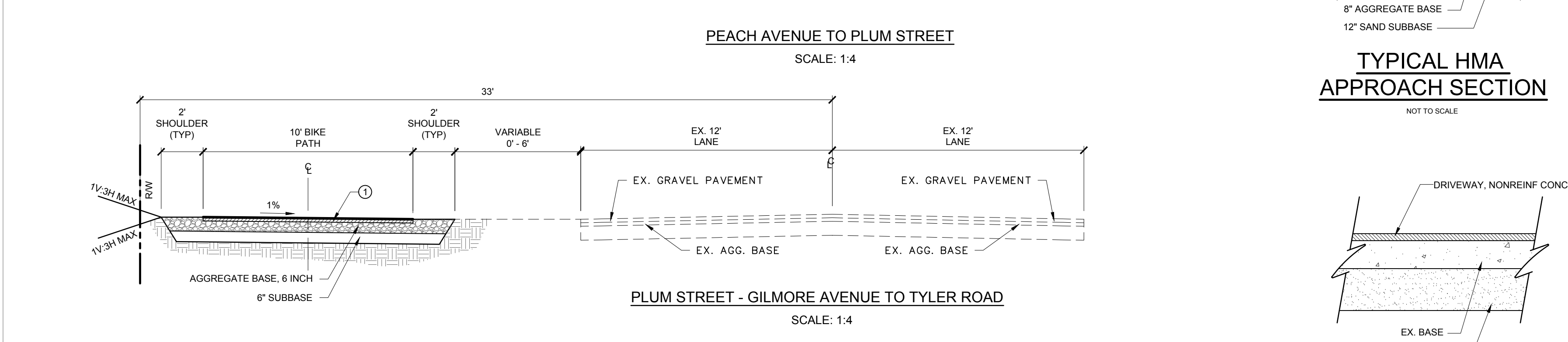
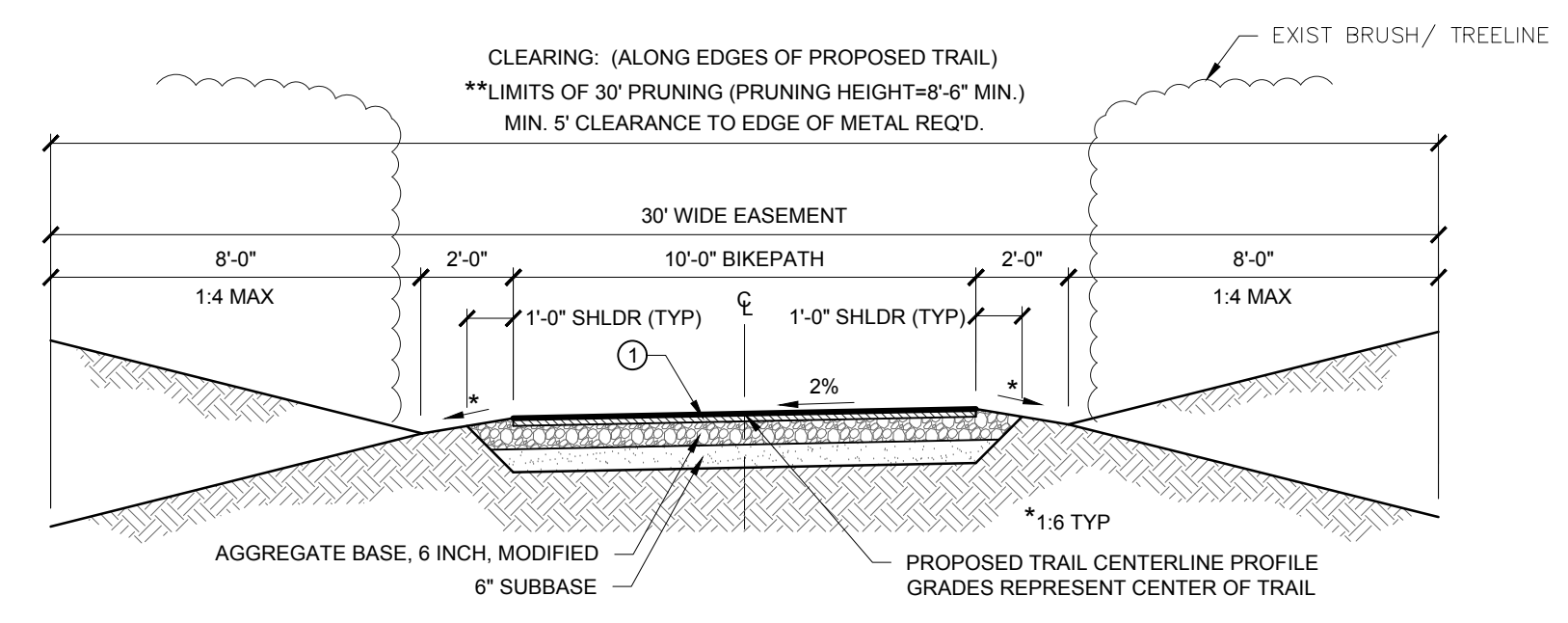
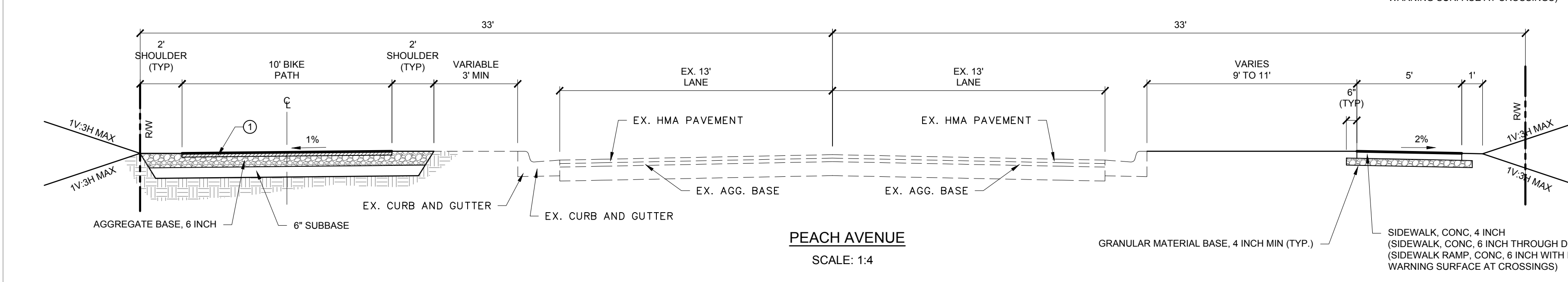
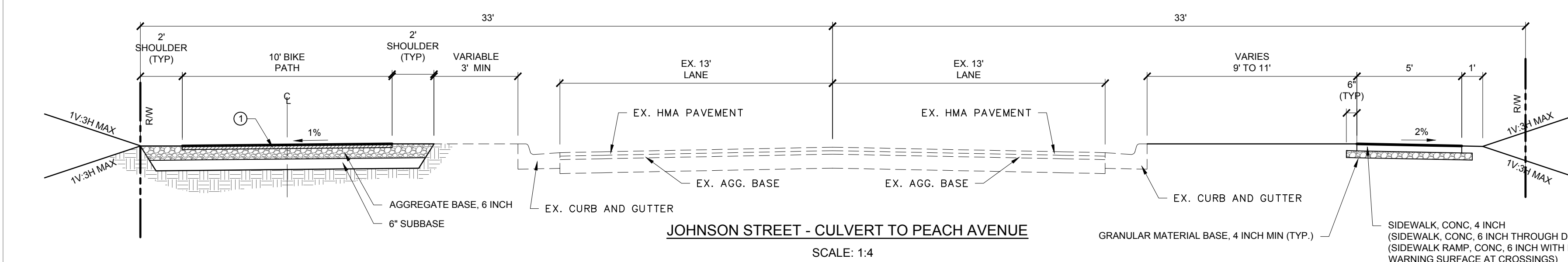
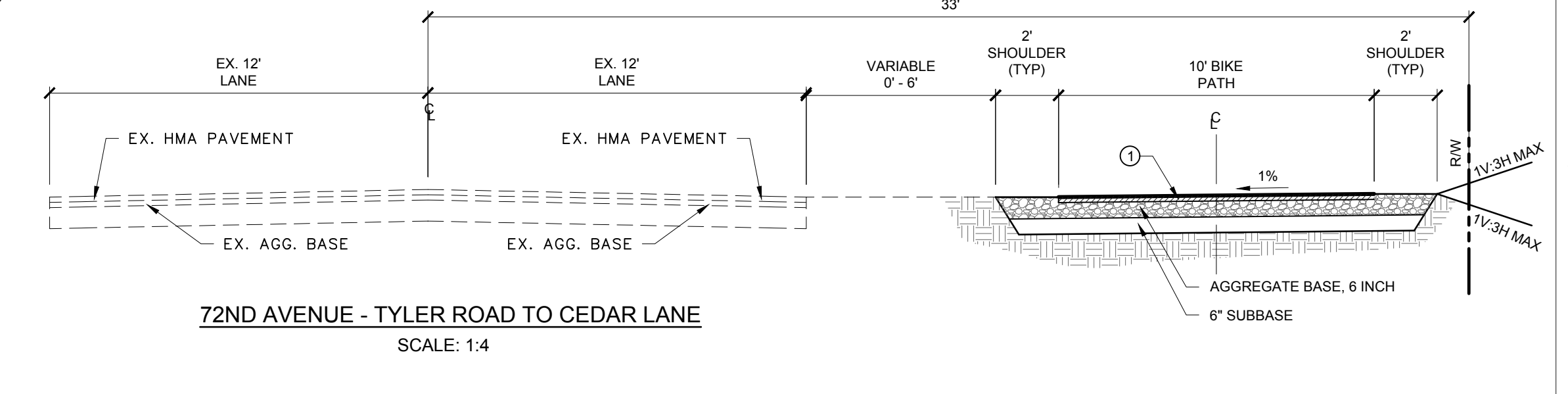
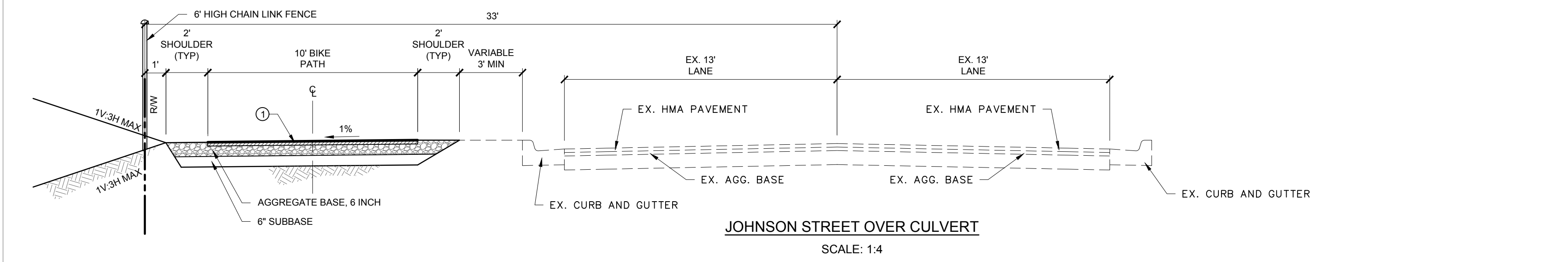
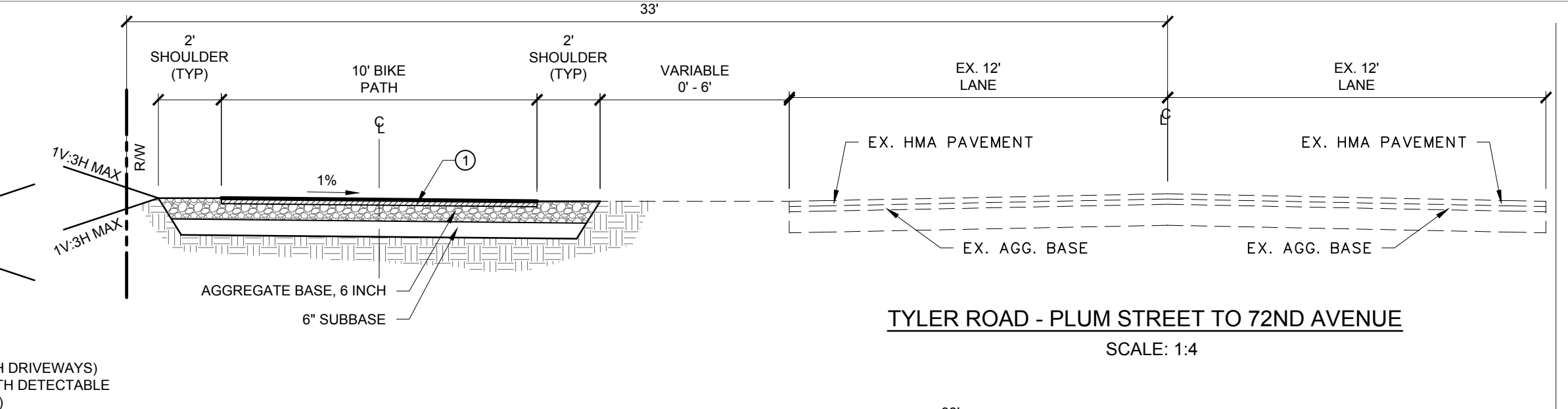
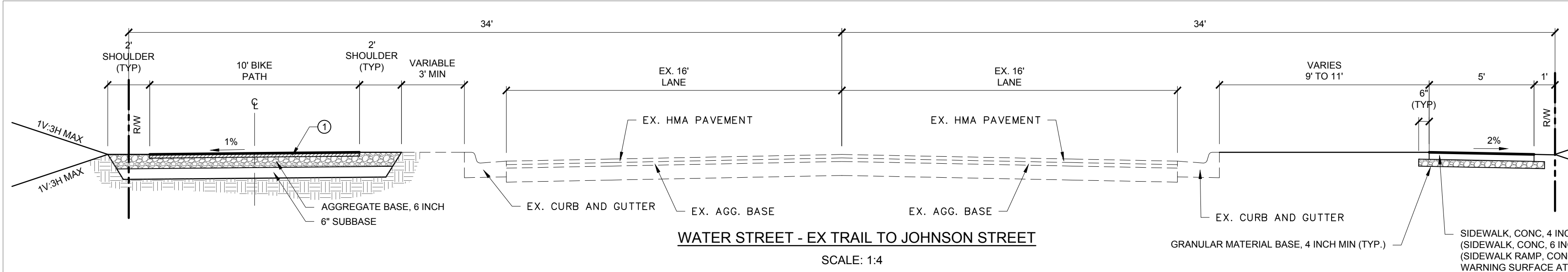

HMA APPLICATION TABLE						
COURSE	TYPE	ITEM	EST. YIELD	BINDER GRADE	AWI	REMARKS
①	SHARED USE PATH	HMA, LVSP	220 LBS/SYD	PG 58-28	-	
②	DRIVEWAY	HMA APPROACH	330 LBS/SYD	PG 58-28	-	2 EQUAL LIFTS OF 165 LB/SYD HMA, LVSP

CONSTRUCTION NOTES

- SOIL EROSION CONTROL MEASURES**
TO PROTECT SLOPES AND DITCHES, SOD OR SEED / MULCH SHOULD BE PLACED AS SOON AS POSSIBLE. TEMPORARY SOIL EROSION AND SEDIMENTATION CONTROL MEASURES SHALL BE UTILIZED DURING CONSTRUCTION IN ACCORDANCE WITH THE MDOT STANDARD PLANS.
- PLAN ELEVATIONS**
ELEVATIONS SHOWN IN THESE PLANS ARE BASED ON USGS DATUM.
- UNDERGROUND UTILITIES**
FOR PROTECTION OF UNDERGROUND UTILITIES, THE CONTRACTOR SHALL DIAL 1-800-482-7171 A MINIMUM OF THREE WORKING DAYS EXCLUDING SATURDAYS, SUNDAYS & HOLIDAYS PRIOR TO EXCAVATING IN THE VICINITY OF UTILITY LINES. ALL "MISS DIG" PARTICIPATING MEMBERS WILL THUS BE ROUTINELY NOTIFIED. THIS DOES NOT RELIEVE THE CONTRACTOR OF THE RESPONSIBILITY OF NOTIFYING THE UTILITY OWNERS WHO MAY NOT BE PART OF THE "MISS DIG" ALERT SYSTEM.
- PUBLIC UTILITIES**
THE EXISTING UTILITIES LISTED BELOW AND SHOWN ON THESE PLANS REPRESENT THE BEST INFORMATION AVAILABLE. THIS INFORMATION DOES NOT RELIEVE THE CONTRACTOR OF THE RESPONSIBILITY TO SATISFY HIMSELF AS TO THEIR ACCURACY OR HIS RESPONSIBILITY IN CASE UTILITIES HAVE BEEN CONSTRUCTED OR REMOVED.
- | | | | |
|-------------------------|--|--------------------|---|
| GAS | MICHIGAN GAS UTILITIES CORPORATION
899 TELEGRAPH ROAD
MONROE, MI 48161
P 517.252.5238
ATTN: JIM NEWBY
jim_newby@cable.comcast.com | ELECTRIC | CONSUMERS ENERGY
1955 W. PARNALL ROAD
JACKSON, MI 49201
P 517.788.2490
ATTN: DAVID SOUTHWARD
dsouthward@cmsenergy.com |
| CABLE TELEVISION | COMCAST
16718 U.S. 12
CEMENT CITY, MI 49233
P 517.252.5238
ATTN: JIM NEWBY
jim_newby@cable.comcast.com | TELEPHONE | VERIZON/FRONTIER
340 S. MAIN STREET
ADRIAN, MI 49221
P 517.265.0649
ATTN: MARK SPINA
mark.spina@tr.com |
| WATER/SEWER | CITY OF HUDSON
40 JACKSON ST.
HUDSON, MI 49220
P 517.448.6101
ATTN: PHIL GOODLOCK | FIBER OPTIC | D & P COMMUNICATIONS
124 TECUMSEH STREET
DUNDEE, MI 49220
P 734.279.1339 X5502
ATTN: JAMES PLOTTIS
james.plottis@d-pcomm.com |

- DRIVEWAYS**
CONTRACTOR SHALL MAINTAIN ACCESS TO DRIVEWAYS DURING CONSTRUCTION WITH 22A AGGREGATE OR BITUMINOUS MILLINGS, INCLUDED IN MINOR TRAF DEVICES PAY ITEM.
- SURFACE RESTORATION**
INCLUDED IN SHARED USE PATH, HMA PAY ITEM.
- TREES/ PRUNING/ CLEARING**
BRANCHES THAT ARE TRIMMED ARE TO BE PRUNED AT TRUNK (TYP. ALL SECTIONS) PRUNING OF TREES SHALL BE PAID FOR AS PART OF SHARED USE PATH, GRADING AND NOT PAID FOR SEPARATELY. TREE AND STUMP REMOVAL ALONG EDGES OF TRAIL AND NOT WITHIN "GRADING" AREAS WILL BE PAID FOR AS "CLEARING".
- RIGHT-OF-WAY**
ALL ACCESS TO WORK ALONG THE RIGHT-OF-WAY SHALL BE ALONG PROPOSED BICYCLE PATH ROUTE WITH ENTRANCES AT N. MAPLE GROVE AVENUE AND MEADOWBROOK DRIVE OR N. MUNSON HIGHWAY.

STANDARD PLANS

- CONSTRUCTION OF THE FOLLOWING ITEMS WHERE CALLED FOR ON THE PLANS, WILL BE CONSTRUCTED ACCORDING TO THE MICHIGAN DEPARTMENT OF TRANSPORTATION STANDARD PLANS UNLESS OTHERWISE INDICATED.
- | | |
|---|-----------------------------------|
| STANDARD PLANS | M.D.O.T. STANDARD PLAN NO. |
| MONUMENT BOXES | R-11-E |
| COVER G | R-12-E |
| COVER K | R-15-G* |
| COVER Q | R-18-F |
| SIDEWALK RAMP AND DETECTABLE WARNING DETAILS | R-28-J* |
| DRIVEWAY OPENINGS & APPROACHES AND CONCRETE SIDEWALKS | R-29-I |
| CONCRETE CURB AND CONCRETE CURB & GUTTER | R-30-G |
| GRANULAR BLANKET, UNDERDRAINS, OUTLET ENDINGS FOR UNDERDRAINS AND SEWER BULKHEADS | R-80-E |
| UTILITY TRENCHES | R-83-C |
| SOIL EROSION & SEDIMENTATION CONTROL MEASURES | R-96-E |
| SEEDING AND TREE PLANTING | R-100-H |

- TRAFFIC AND SAFETY STANDARD PLANS**
- | | |
|---|------------|
| GROUND DRIVEN SIGN SUPPORTS FOR TEMPORARY SIGNS | WZD-100-A* |
| TEMPORARY TRAFFIC CONTROL DEVICES | WZD-125-E* |
| * DENOTES SPECIAL DETAIL INCLUDED IN PROPOSAL | |

- PERMANENT PAVEMENT MARKINGS**
- | | |
|---|------------|
| PAVEMENT ARROW AND MESSAGE DETAILS | PAVE-900-F |
| LONGITUDINAL LINE TYPES AND PLACEMENT | PAVE-905-D |
| INTERSECTION, STOP BAR, AND CROSS WALK MARKINGS | PAVE-945-C |
| BIKE LANE AND PATH PAVEMENT MARKINGS | PAVE-962-A |
| * DENOTES SPECIAL DETAIL INCLUDED IN PROPOSAL | |

M:\Vp\847680-849000\847680_Hort - Safe Routes to School Application\Doc\Plan\847680_C501.dwg - plotted on 1/12/2021 11:55 AM

RESOLUTION 2021-03

RESOLUTION SUPPORTING A SAFE ROUTES TO SCHOOL GRANT APPLICATION

WHEREAS, the Safe Routes to School program is a federally funded program administered in Michigan by the Michigan Department of Transportation (MDOT); and

WHEREAS, the City of Hart in partnership with Hart Public Schools, the Pentwater-Hart Trail Committee and the Oceana County Road Commission, is applying for funds through MDOT from the Safe Routes to School program to construct certain infrastructure projects throughout the City, including multifunctional pedestrian/bicycling pathways and sidewalk, crossing, and signage to enable and encourage children to safely walk and bike to school; and

WHEREAS, MDOT requires a formal commitment from the public agency that will be receiving these funds and will be implementing and maintaining these infrastructure projects.

NOW, THEREFORE, BE IT RESOLVED, that the City has authorized Lynne Ladner, City Manager and Act 51 Street Administrator, to act as agent on behalf of the City to request Safe Routes to School funding, to act as the applicant's agent during the project development, and to sign a project agreement upon receipt of a funding award; and

The City attests to the existence of, and commits to, providing in collaboration with the Pentwater-Hart Trail Committee the funds necessary to carry out the project (\$25,000 from the City of Hart, \$440,000 in grant funding and \$246,855 from the Pentwater-Hart Trail Committee funds), including engineering design and construction, permit fees, administration costs, and cost overruns; and

The City commits to owning, operating, funding, and implementing a maintenance program over the design life of the facilities constructed with Safe Routes to School funding.

Moved by _____, supported by _____, and thereafter adopted by the Hart City Council at a regular council meeting held on January 26, 2021.

Ayes: Nays: Absent:

I hereby certify this to be a true and correct copy of the document on file with the office of the City of Hart Clerk.

Karla Swihart, City Clerk

Memo

To: Mayor and Council
From: Lynne Ladner
Date: 1/22/2021
Re: Resolution 2021-03 Support for SRTS grant application

Ladies and Gentlemen,

I have been in discussion with neighboring Shelby Township regarding a request to potentially provide the Township with Community and Economic Development assistance. I have included Nichole in the discussions as she would be the individual that would be assisting the township. We have reached the point where we believe we have outlined a mutually beneficial arrangement which is detailed very high level below. Unless there is substantial disagreement from the Council related to moving forward to the next step which would be to draft an intergovernmental agreement between the two parties for final review and approval by both governing bodies I will proceed with these discussions and drafting an agreement.

How can the City of Hart assist Shelby Township?

Grant Writing

Marketing assistance – newsletter, event material design, advertising design

Represent Shelby Township in addition to City of Hart at County-wide community and economic development meetings.

How Can Shelby Township assist the City of Hart?

Annual allocation of \$ _____ in return for on average 8 hours per week of assistance to township. Hours to vary by week/month based on township and city project needs.

Outline of related City of Hart goals.

Enter into intergovernmental agreement with Chamber to assist in financing currently approved part-time (up to 20 hours/week) Event Planner allowing the position to be full time with stipend for Health Care and therefore more attractive to candidates.

Approach National Asparagus Festival Committee to provide year-round festival and related events planning by the contracted Event Planner in return for financial assistance.

Explore reimagining/redesigning the downtown City of Hart – HEART offices to create local marketplace for Oceana County entrepreneurs to market and sell goods providing entrepreneurs from The Starting Block with an opportunity to market their goods (this would not include direct marketed goods such as Tupperware, Shakeology, Pampered Chef, etc.), provide a small business resource center and first come scheduled conference room. Lastly, reconfigure rear of existing space to provide office space for City of Hart Economic and Community Development Director, Joint Event Planner, transitional shared office space for local and visiting entrepreneurs on a first come-first served hourly use with access to all utilities, office equipment (printers, copiers, and business phone).

Lynne



HEART ECONOMIC AND REDEVELOPMENT TEAM

Hart Councilmembers,

The Hart Economic & Redevelopment Team at its January 20, 2021 regular meeting moved to accept the attached “Boards and Commissions Member Application” submitted by Nicole Russell, requesting to join the H.E.A.R.T. Board of Directors.

H.E.A.R.T. respectfully requests that City Council accept its recommendation to appoint Nicole Russell to the H.E.A.R.T. Board of Directors.

Respectfully Submitted,

Nichole Steel, Director
Hart Economic & Redevelopment Team
City of Hart

BOARD OF DIRECTORS

Rob Splane
President

Jake Tufts
Vice-President

Brandon Bruce
Treasurer

Scott Beal
Secretary

Tracy Lipps
Director

Braxton Platt
Director

Brandi Bruch
Director



City of Hart
407 S. State St.
Hart, MI 49420

BOARDS – COMMITTEES - COMMISSIONS
APPLICATION FOR APPOINTMENT - REAPPOINTMENT TO
SERVE ON CITY ADVISORY BOARDS – COMMITTEES - COMMISSIONS

- | | |
|--|---|
| <input type="checkbox"/> Power Board | <input type="checkbox"/> Planning Commission |
| <input type="checkbox"/> Water/BioPure Board | <input type="checkbox"/> DPW Board |
| <input type="checkbox"/> Hart Lake Improvement Board | <input type="checkbox"/> Zoning Board of Appeals |
| <input type="checkbox"/> Housing Board of Review | <input type="checkbox"/> Neglected Properties Board |
| <input type="checkbox"/> Park Committee | <input type="checkbox"/> TIFA |
| <input type="checkbox"/> Other _____ | <input checked="" type="checkbox"/> Hart Economic & Redevelopment Team H.E.A.R.T. |

PLEASE CHECK OFF THE BOARDS/COMMITTEES/COMMISSIONS YOU ARE INTERESTED IN SERVING ON.

Name: Nicole Russell Home Phone: None

Home Address: 1854 N. 56th Ave Mears, MI 49436

Employer Address: 4086 W. Pdk Rd. Hart MI 49420

Work Phone: 231-301-8226 Cell Phone: 231-742-2390

Email Address: nikki@bighartbrewing.com or russell_nikki@hotmail.com

What special experience, education or interest do you have for serving on each of the board(s), committees(s), commissions(s) you selected?

As the Assistant General Manager of Big Hart Brewing Co., I am very passionate about bringing positive attention to the great City of Hart! I believe we have a lot to offer as a community, and I feel as though I have a lot to offer

What other board(s), committee(s), and commission do you currently serve on or have served on in the past?

I currently do not serve on any but look forward to perhaps one day serving this community as I serve Big Hart!

Signature: Nicole Russell Date: 1-12-20

Please return completed application to:
City of Hart
Lynne Ladner, City Manager
407 S. State St.
Hart, Michigan 49420
Fax: 231-873-0100

City use only:
Date of Approval: _____

Hart Economic & Redevelopment Team (H.E.A.R.T.)

Members are appointed by the City Council. Members must be city residents, experience and/or training in matters related to the committee preferred. Please check below if you have experience in:

- Education
- Infrastructure (buildings, roads, power supplies)
- Regional Collaboration (forming cooperative relationships among local governments and stakeholders)
- Industry Activities (recruiting, retaining and growing all types of business)
- Destination Marketing (attracting visitors and improving quality of life to attain new residents, business and investment)